



# WHOLE HOUSE WATER SOFTENING SYSTEMS INSTALLATION AND SERVICE MANUAL



## TABLE OF CONTENTS

---

Application Limitations.....	3
System Information .....	4
Maintenance Requirements .....	5
Pre-Installation Instructions .....	5
Installation Instructions .....	6
Control Information .....	10
Start Up Instructions .....	11
Programing The Control.....	14
Understanding the Diagnostic Level .....	19
Sanitizing the Softener .....	20
Exploded Views and Parts Lists .....	21-27
Troubleshooting Guide.....	28-30
Performance Data Sheet.....	31

## IMPORTANT INFORMATION

---

- Read these instructions carefully and determine the location of all system components before beginning installation.
- Check all applicable plumbing, building, and electrical codes for installation compliance.
- Install the system on the main water supply.
- The use of plumbers tape and/or pipe thread seal paste will be needed on all threaded connections.
- To condition all water in the home, install the water softening system close to the water supply inlet, and upstream of all other plumbing connections, except outside water pipes. Outside faucets should remain on unfiltered water.
- Systems that contain electronic components cannot be installed outside in uncovered areas.

### **WARNING**

Installing this system in a metal (conductive) plumbing system, i.e., copper or galvanized metal, will interrupt the continuity of the plumbing system and grounding source in some homes. If your home's electrical appliances are grounded through the plumbing system, you will need to install a bypass that consists of the same material as the existing plumbing or a grounded "jumper wire" to bridge the equipment and re-establish the contiguous conductive nature of the plumbing before using this Pentair system. Failure to do so can result in errant electricity from improperly grounded appliances or potential galvanic activity in the plumbing system, which could increase the risk of fire or injury

### **CAUTION**

When adding a filtration/softening system to homes/buildings supplied by well water, the system should be installed following the pressure tank. **DO NOT USE this system for pneumatic or hydropneumatic applications. If you are using a booster pump, then install this system following the booster pump.** If you have questions, please call customer

<h3>Customer Service Contact Information Section</h3>	
Homeowners Phone: 877.842.1635	Professionals Phone: 800.811.3489

## **APPLICATION LIMITATIONS**

---

- This system may be applied on municipality or well water systems. On hardness levels of 60 grains and higher, the system may not achieve a hardness of less than 1 grain, due to high Total Dissolved Solids (some bleed through is possible). Bleed through can also be caused by sodium levels higher than 1000 ppm. In either case, your system can be programmed to minimize these effects. See page 10.
- When this system is installed on water with ferrous iron, also known as clear water iron, the maximum range of reduction is based on local water conditions. The range is generally below 3 parts per million. Your equipment may require special programming, along with an additive to the brine tank, to maximize the equipment's ability to reduce iron. See page 10.

## SYSTEM INFORMATION

---

### POWER REQUIREMENTS

The computer board receives power from an external wall-mount transformer, supplied with each system.

**Voltage:** The voltage supplied to the computer board is 24V AC.

**Frequency:** The line frequency is 50 Hz or 60 Hz.

### WATER PRESSURE

A minimum of 20 pounds of water pressure is required for proper operation of the system. The stated operating pressure range is 20 psi - 120 psi (138 kPa - 828 kPa).

### BYPASS VALVE

The bypass valve enables the customer to bypass the system in situations of: emergency leaks in the equipment, service calls and/or outdoor water use.

### TEMPERATURE OPERATING RANGES

Operating Temperature Range: 40° F - 100° F (4.4° C - 38° C)

Storage Range: The computer board can be stored at temperatures -20°C (-4°F) - 70°C (158°F).

Humidity: The computer board operates properly with relative humidity 10% - 95%, non-condensing.

### ENVIRONMENTAL REQUIREMENTS

Location: The water softener and control cannot be exposed to outdoor elements, such as direct sunlight or atmospheric precipitation. The system may be installed in a covered, open-air structure such as a carport, residential or commercial building. Weather covers are also available through the Order Department (part number 72370).

## OPERATIONAL SPECIFICATIONS

---

UNIT SIZE	MODEL	SERVICE FLOW RATE (GAL/MIN)	PSI DROP AT SERVICE FLOW RATE	DRAIN FLOW RATE (GAL/MIN)	CAPACITY AT LOW SALT SETTING (GRAINS)	CAPACITY AT MEDIUM SALT SETTING (GRAINS)	CAPACITY AT HIGH SALT SETTING (GRAINS)	EFFICIENCY (GRAINS/LB. OF SALT)
1.0	PENTAIR WATER SOFTENING SYSTEM 1.0	10.0	9	2.5	16,660 @ 3.9 LBS	24,593 @ 7.9 LBS	30,726 @ 15.8 LBS	4272
1.5	PENTAIR WATER SOFTENING SYSTEM 1.5	11.8	15	2.5	24,990 @ 5.8 LBS	36,889 @ 11.8 LBS	46,089 @ 23.7 LBS	4272
2.0	PENTAIR WATER SOFTENING SYSTEM 2.0	14.5	15	3.5	33,332 @ 7.8 LBS	49,186 @ 15.8 LBS	61,452 @ 31.6 LBS	4272



SYSTEMS TESTED AND CERTIFIED BY WQA ACCORDING TO NSF/ANSI 44 FOR THE REDUCTION CLAIMS SPECIFIED ON THE PERFORMANCE DATASHEET, CSA B483.1 AND NSF/ANSI 372.

## **MAINTENANCE REQUIRMENTS**

---

### **SALT RECOMMENDATIONS**

Two kinds of salt are recommended for water softeners:

1. Block Salt: Water softener block salt is reasonably priced, low in impurities and will not cake in the salt container. Block Salt is pressed into the shape of a cattle block.
2. Solar Salt: Solar Salt is 98% pure salt, reasonably priced and low in impurities. Solar Salt is in the shape of pellets.

### **THE REGENERATION VALVE**

The regeneration valve is designed to last many years, but from time to time it may be necessary to clean and lubricate the moving parts. Your water quality and the amount of regenerations necessary will affect this maintenance schedule.

### **TESTING THE WATER**

The water should be tested periodically (2 times a year minimum) with hardness test strips to ensure that the system is performing accurately.

## **PRE-INSTALLATION INSTRUCTIONS**

---

- Do not install this system where water is microbiologically unsafe or of unknown quality without adequate disinfection before or after the system.
- This system must be installed in an area that is not affected by extreme heat, cold or the elements. The selected installation area must be adequate for easy service of all parts.
- This system must be installed in accordance with all applicable state and local laws and regulations.
- This system is designed to treat cold water only and can be installed on any cold water supply.

# INSTALLATION INSTRUCTIONS

---

## 1. SAFETY PRECAUTIONS

- To prevent accident or injury, do not hoist the unit over your shoulder. Use a hand truck to transport the unit.



### Notice

**Do not lay the unit on its side during transportation and/or installation.**

- Wear safety glasses and work gloves during installation and service.

## 2. TEST THE WATER HARDNESS

- The test strip provided is for testing the water hardness after the installation is complete to ensure the system is functioning properly and for periodic testing. When programming the control it is necessary to know the exact water hardness in grains per gallon. If you are using municipal water, your local water providers should be able to give you the hardness level. If you are using water from a private well, it may be necessary to have the water tested locally.

## 3. CHECK WATER PRESSURE

- Use a pressure gauge to confirm that the water pressure does not exceed 120 psi. If the water pressure does exceed this limit, install a pressure regulator on the inlet pipe of the unit. The minimum pressure for a conditioner is 20 psi. 60 psi is the optimum operating pressure.

## 4. LOCATE A SITE FOR THE UNIT

- There are three primary requirements needed for a site: the main water source, a drain (the drain may be a floor drain, a sewer trap, utility sink, vent stack, dry well, etc., depending on local plumbing codes) and an electrical connection. Locate the system as close to these items as practical. Avoid drain lines over 25 feet long. In most applications, bypass any outside faucets.
- Place the unit in the desired location. The location must have a level, smooth surface.
- If the system is located outdoors, protect the unit from direct sunlight. (Direct sunlight can damage the fiberglass and other system components.) If necessary, build a box or shed.



### Notice

**The system can only be installed outdoors in climates that do not reach freezing levels.**

## **INSTALLATION INSTRUCTIONS CONTINUED**

---

### **5. TURN OFF THE WATER AND DRAIN THE PLUMBING**

- Turn off the water at the meter or the pressure tank.
- Drain all the pipes. Do not sweat the pipes with water in them; steam will damage plastic parts in the valve.
- To drain the plumbing system, open all the faucets in the house and flush the toilets. This procedure will allow air to enter the plumbing system. The water will drain out of the lowest faucet or outlet.

### **6. BYPASS THE OUTSIDE FAUCETS**

- When possible, it is best to bypass the outside faucets. However in some cases the outside faucets cannot be accessed. In this situation, the bypass valve should be used whenever watering outside for extended periods of time. If the installation is outside or in a garage, a faucet can be installed on the inlet water side to provide an option for untreated water.

### **7. CONNECT THE PLUMBING TO THE BYPASS VALVE AND BRINE TANK**

- Do not point the soldering torch directly at the system. The thermo-plastic material will last a lifetime, within normal operating temperatures, but will melt in a torch flame.
- To prevent hot water from backing up into the conditioner, avoid short connections of pipe between the softener and the hot water heater. If you can't avoid a short connection, move the equipment to another location. As a last resort, install a check valve. If the check valve causes "water hammer", install a water hammer suppressor.

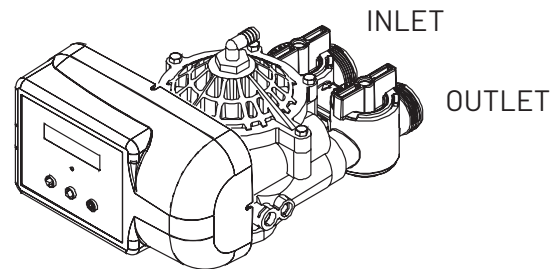

- Connect the raw water pipe to the INLET pipe connection of the bypass valve. When looking at the front of the unit, the inlet is the pipe connection on the LEFT side of the valve.
- Connect the treated water pipe to the OUTLET pipe connection of the bypass valve. When looking at the front of the unit, the outlet is the pipe connection on the RIGHT side of the valve.
- Install the brine line to the brine tank.

## 8. PLUMBING GROUND CONNECTION

- In some homes, metal piping may serve as a ground connection for the home electrical system. Installing a Pentair Softener with its nonmetallic valve body will interrupt the ground connection. Whenever a system is installed on metallic plumbing, we recommend you use grounding pipe clamps and a ground cable to maintain continuity of the ground connection from the inlet to the outlet pipe. ¼" bare stranded wire is recommended for the ground cable. Check electrical continuity of the connection after installation.

## 9. INSTALL THE DRAIN LINE AND AIR GAP (AIR GAP NOT INCLUDED WITH THE UNIT)

- Using the supplied drain line fitting, use plumbers tape on the threads and attach to the top of the valve. Run 1/2 inch I.D. flexible drain line tubing (not supplied) to an appropriate drain. Most local codes require an air gap. See pictures below.



### Notice

Drain line may be plumbed with rigid pipe or PEX, if required by local code. The drain connection on the valve will accommodate any standard 3/4 inch NPT fitting.

- If you wish to use an air gap device (not included) you may purchase one from the Order Department.

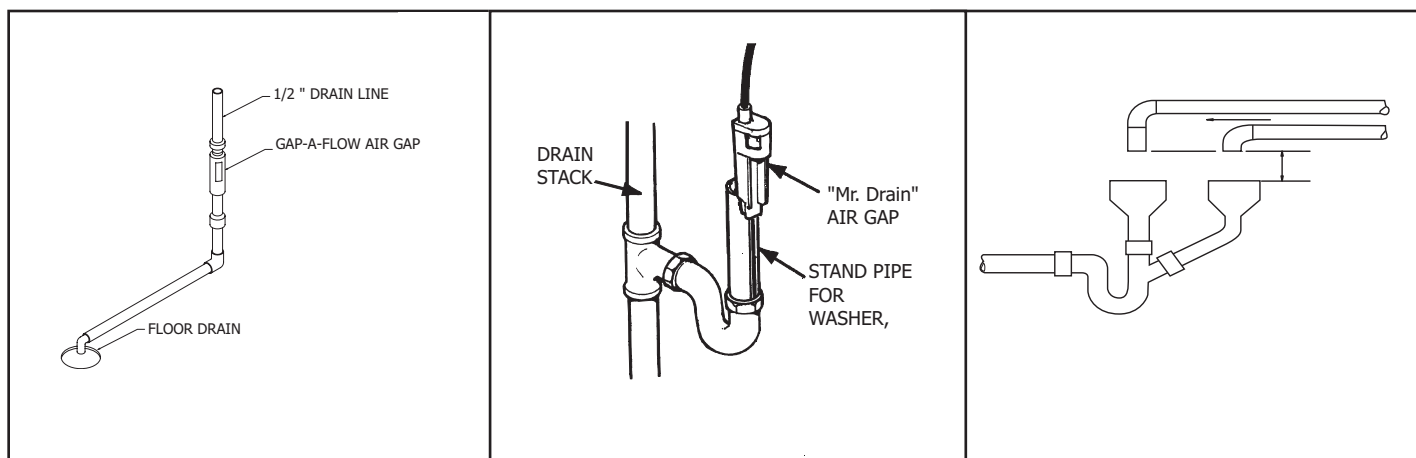

Air Gap Floor Drain  
Part Number: 13142

Air Gap Mr. Drain,  
Part Number: 14199

Standard Air Gap



**Special Attention for situations where a Filter and a Softener are installed together:**

When a whole house filter and a softener are installed side by side, the preferred approach is to run a separate drain line from each unit all the way to the point of termination. If this is not done, there is the potential for drain water from the filter to back feed through the softener and overflow the brine tank, especially when drain lines are run overhead. (Please note that back feed goes only into the brine tank, not the service line.)

If circumstances require you to tie the drain lines together, please use one of the following methods to avoid back feed issues:

**Option 1:** Run the drain lines from both systems to the point of termination, and tee them together before the air gap. (See figures below)

**Option 2:** Install a PVC check valve with a light spring on the Softener side to prevent back flow to the Softener. (See figure below)

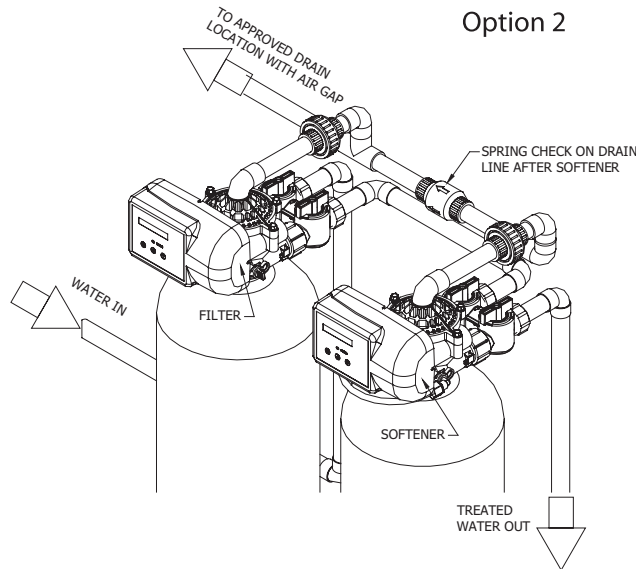
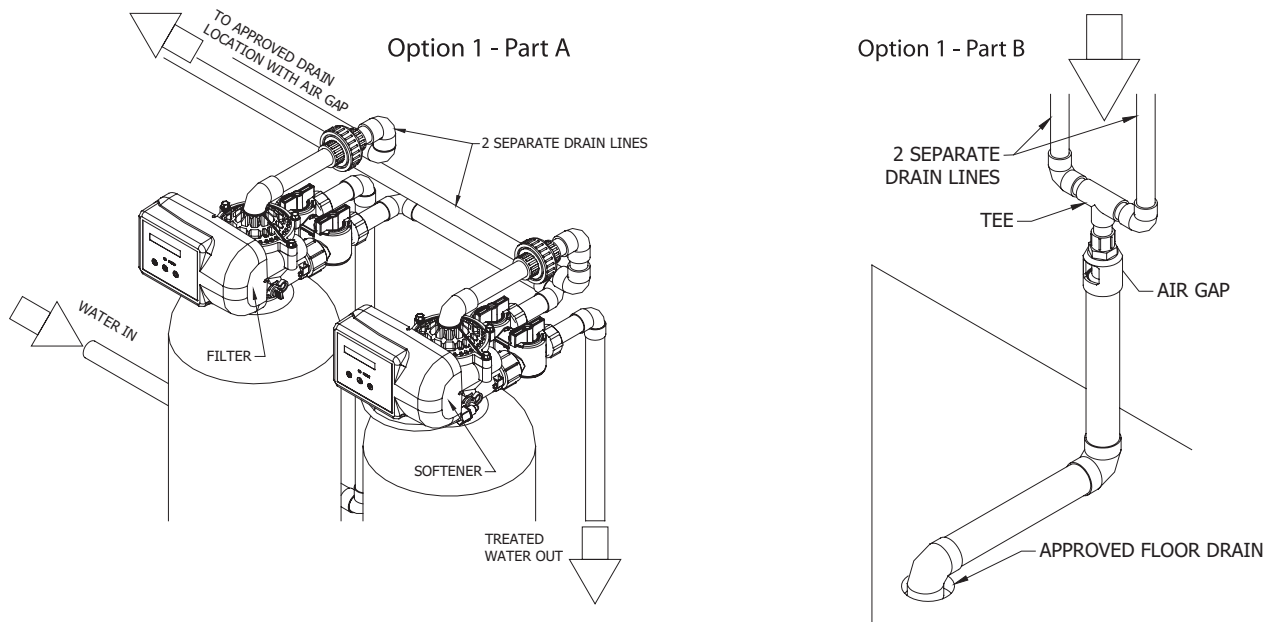

## **CONTROL INFORMATION**

---

### **POWER ON LED**

A green LED is ON when power is applied to the control and the microprocessor is operating properly.

### **SERVICE REQUIRED**

If the message "For Service Call" or "Service Required" displays in the window of the control without showing the time of day, the control valve has encountered a problem, such as failure to reach the proper position during regeneration. The valve, the motor assembly, and board must be checked to diagnose and fix this problem.



### **Notice**

**It is normal for the message 'For Service Call' followed by a phone number to scroll across the second line of the display. The time of day & capacity remaining will appear on line 1 during normal operation.**

### **TIME CLOCK**

The time clock maintains the time of day for an extended period of time in the event of power loss. A super capacitor provides this function and eliminates the need of a battery. In the event the power is off past the charge of the capacitor only the time of day is lost. The rest of the programming is stored in the memory and will not need to be reprogrammed. When the power is restored the clock will restart at 8 AM and will need to be reset.

### **REGENERATION**

Once an immediate regeneration is requested, a complete regeneration must occur to clear the request. Once the regeneration starts, it must finish or the computer board will not clear. Manually walk (scroll) the control through regeneration to clear the computer board. If the regeneration is aborted and the request is not cleared, another immediate regeneration will occur.

### **HIGH-SPEED MOTOR OPERATION IN THE REGENERATION MODE**

High-speed motor operation is achieved while stepping the control through the regeneration cycle. Pressing the scroll button a second time, while in regeneration, activates the higher speed.

### **PROGRAM LEVELS**

To enter any of the program levels, the control must display the time of day and gallons of capacity remaining (Service Mode).

The system has three program levels available:

1. The Installer's Level: To access the Installer's Level, you must enter the five key sequence code located on page 9. Please refer to pages 10-13 for programming information.
2. The End User's Level: The End User's Level does not require a special code to access. Please refer to page 13 for programming information.
3. The Diagnostic Level: Please refer to page 14 for information.

## **QUICK START GUIDE: SYSTEM START-UP INSTRUCTIONS**

---

1. **Connect the unit to the existing plumbing**  
(Facing the front of the system, **the INLET is on the LEFT –the OUTLET is on the RIGHT**)



### **Notice**

**The bypass is only hand tightened at the factory and must be fully tightened and checked for leaks by installer.**

Connect the drain line to a proper location; adhere to ALL LOCAL and STATE CODES.

When turning the water back on, leave the system in bypass mode and then turn water on to house and check for leaks. Run the cold water in bathtub or outdoor faucet to flush debris and air from lines. (Bathtubs and outdoor faucets do not have aerators that may plug with debris.) Then once the programming is complete, follow start up procedure starting at step 10.

2. **Understanding the face plate**  
There are 3 buttons on the face of the unit.  
The button on the left with the 2 arrows in a circle is called the scroll button.  
To the right are the up and down button.
3. **Programing the system**  
To begin, place the control into the service mode.  
Press and hold the DOWN arrow for 5 seconds; the control will display: **SYSTEM CHECK**  
Then enter the following code by pressing and releasing the following buttons.  
**DOWN, DOWN, SCROLL, DOWN**, THIS MUST BE DONE WITHIN 10 SEC. or the control will return to the home screen. The screen will display **"UNIT SIZE 1.5"**. Use the UP or DOWN arrow to set the size of the system, **1.0, 1.5, or 2.0**.
4. **Set the Hardness**  
Press the SCROLL to advance to the next setting.  
The control will display **"WATER HARD: 20 GRN"** use the UP or DOWN arrow to adjust to correct hardness of the water (if iron is present adjust Hardness +5 for every 1ppm of iron). When you adjust the hardness, the unit will change the necessary settings automatically.
5. **Salt Setting**  
Press the SCROLL to advance to the next setting.  
The control will display **"SALT LEVEL: MED"**. This is the standard setting. In most all cases leave at the factory setting.  
If the hardness is above 50 grains use the UP arrow to change to **"HIGH"**.  
If it's 10 or less you may use the DOWN button to change to **"LOW"**. Note Using a low salt setting will save salt but the system will use twice as much water.  
The refill time will adjust automatically to use more or less salt to REGENERATE.
6. **Enter desired phone number.**  
Press the SCROLL button to advance to the next setting.  
The screen will read **"CHANGE PHONE? NO"** use  
DOWN button change to **"YES"** Press the SCROLL button 1 time and the 1st number will flash.  
Use the UP or DOWN button to program your phone number to display. After each number press the SCROLL button 1 time to advance to the next number. After setting all the numbers, press SCROLL to advance to the next setting.
7. The control will display **"TIME OF DAY"**, press the UP or DOWN arrow to program the time of day.

## **QUICK START GUIDE: SYSTEM START-UP INSTRUCTIONS CONTINUED**

---

### **8. Optional advanced menu:**

Press the SCROLL button to advance to the next setting.

The control will then display **"Go to ADVANCED menu? No"**

If you want to view the advanced settings, press the UP or DOWN arrow, change to "YES" and press the SCROLL button (Default settings on ADVANCED MENU will not need to be changed for most applications).

\*The ADVANCED MENU consist of **RESET AVERAGE: NO, RESERVE CAPACITY: VARIABLE, TIME OF REGENERATIONS: 2 AM, DAYS OVERRIDE: OFF, BACKWASH: 10min, BRINE/SLOW RINSE**

9. If you don't want to access the advanced settings, leave at "NO". Press SCROLL button 1 time. The control will display **"EXIT: PRESS ↓"**, press DOWN to exit installer's program level. The Time of day and rolling message "For Service, Call (your number)" will be displayed.

### **SYSTEM START UP:**



**When a carbon or any other filter is installed ahead of the softener, perform the start up on that system first, then the softener. This will prevent possible damage to the softener valve**

### **10. Confirm system is plumbed correctly: inlet on left, outlet on right –**

Is the drain properly connected? Place the softener system on bypass. Open a faucet without an aerator, such as a bath tub or outdoor faucet, and close all other faucets. Turn on the water and allow the system to rinse for a few minutes to rinse the plumbing. Next open the bypass valve and rinse the softener. It is normal to see some yellow color throw from the system. That will rinse clear right away.

### **11. Advance to backwash:**

Press the SCROLL button 2 times. The display will start a 10 second count down. At zero the motor will start and advance to cycle 1. Wait for the motor to stop in cycle 1. Air will purge from tank. Allow to run until there is a steady flow of water at the drain.

### **12. Advance to brine and rinse:**

Press the SCROLL button to advance to the next cycle. The motor will start and advance to cycle 2. Wait for it to stop. Disconnect brine line at the brine tank to confirm suction by placing thumb on the end of the tubing, and then leave disconnected for the next step.

### **13. Advance to Fast Rinse/Brine refill:**

Press the SCROLL button to advance to the next cycle. The motor will start and advance to cycle 3. Wait for the motor to stop. Water will flow to the drain and the brine line at the same time. Verify you are achieving the proper flow (0.5 GPM for 1.5 models and 1.0 GPM for the 2.0 model). Then reconnect and lift up on the float in the brine tank while checking all fittings for leaks (this will pressurize the brine connections and is a common mistake).

## **QUICK START GUIDE: SYSTEM START-UP INSTRUCTIONS CONTINUED**

---

### **14. Return to the Home Screen and then advance back to refill:**

Press the SCROLL button to advance to the home position. The control will display the home screen, press the scroll button 2 times. The 10 second Countdown will begin and the cycle will start again. Wait for the motor to stop at cycle 1, then advance by pressing scroll button 1 time. Wait for the motor to stop at cycle 2, then advance to cycle 3 by pressing the scroll button 1 time. Stay in cycle 3 for the duration of the cycle, confirm refill and add salt to the tank. The system will add the correct amount of water to the salt tank.

### **15. Test the cold water and verify meter operation:**

Open a cold faucet, Run the cold water until you achieve soft water. While the water is flowing, check the gallons remaining on the home screen and verify that the number is decreasing. This will confirm that the system is counting gallons. Open a faucet on the hot water side until it turns cold in order to drain the hot water tank to ensure all of the water is treated. Explain the system basics and answer any questions they may have.

## HOW TO CONTROL THE INSTALLER'S LEVEL

---

To

### KEY BUTTONS:

- ⌂ SCROLL BUTTON
- ▲ UP ARROW
- ▼ DOWN ARROW

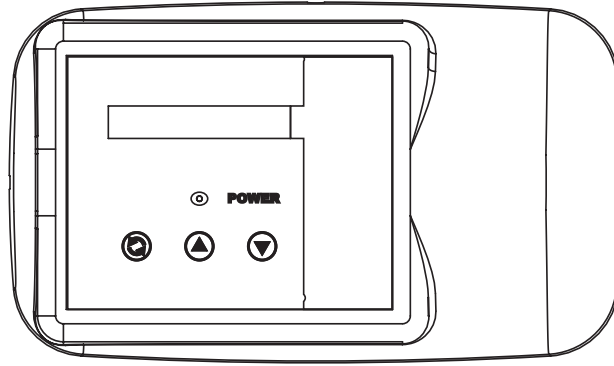

begin, verify that the control is in the Service Mode.

Time of Day GL Remaining

- Press the DOWN ARROW and hold it for 5 seconds; the control will display:

System Check

- Within 10 seconds, enter the following key sequence:

- ▼ DOWN ARROW
- ▼ DOWN ARROW
- ⌂ SCROLL BUTTON
- ▼ DOWN ARROW

The control is now in the Installer's Level. Use the SCROLL BUTTON to advance through the different settings.

The following settings are available in the Installer's Level:

### 1. UNIT SIZE

The control will display:

Unit Size: 1.5

- Press the UP or DOWN ARROW to select a different unit size. Available units are 1.0, 1.5 and 2.0.

**Press the SCROLL BUTTON to advance to the next setting.**

### 2. HARDNESS

The control will display:

WaterHard: 20 Grn

- Press the UP or DOWN ARROW to set the number to the correct incoming hardness, in grains per gallon. The setting range is 1-99.



### Notice

**If you have iron in the water or very high total dissolved solids, you can increase this number for better performance.**

**Press the SCROLL BUTTON to advance to the next setting.**

### 3. SALT LEVEL

The control will display:

Salt Level: Med

- Press the UP or DOWN ARROW to select Low, Medium, or High. Medium is a good setting for most circumstances. For small families and low hardness, Low will provide greater salt efficiency. For large families and high hardness, High will provide the most capacity.

Press the **SCROLL BUTTON** to advance to the next setting.

### 4. SERVICE PHONE NUMBER

The control will display:

Change Phone? No  
000-000-0000

If you do not want to change the phone number, leave this setting at **NO**. Press **SCROLL** to advance to the next setting.

To change the number, select **YES**; Press the **UP** or **DOWN ARROW** and then enter the service phone number. Press **SCROLL** to advance through the digits. After setting the number, press **SCROLL** to advance to the next setting.

### 5. TIME OF DAY

The control will display:

Set Time of Day

- Press the UP or DOWN ARROW to program the time of day.

Press **SCROLL BUTTON** to advance to the next setting

The control will display:

Go to ADVANCED menu? No

If you want to go to the advanced settings, press the **UP** or **DOWN ARROW**, change to **YES** and press the **scroll button**. (see **ADVANCED MENU** on page 16)

If you do not want to access the advanced settings, leave this at **NO**. Press Scroll to advance to the Exit screen.

To Exit Press Down Arrow

Press the DOWN ARROW to exit the Installer's Level.



If you need to recheck settings or make a change, pressing **SCROLL** when "EXIT" is displayed will take you back to the start of Installer Settings.



To active the new settings, you must execute a complete regeneration. If you **DO NOT** manually regenerate the system, the settings **WILL NOT** become active until the unit has completed the next scheduled regeneration.

## ADVANCED MENU

---

### 1. RESET AVERAGE

The control will display:

Reset Average No

- If you want to reset the average daily volume, press the UP or DOWN ARROW to select YES. If YES is selected, the control will reset the average volume per day to 25% of the capacity.

**Press the SCROLL BUTTON to advance to the next setting.**

### 2. RESERVE CAPACITY

The control will display:

Rsrv: Variable

- The reserve capacity will be calculated automatically, based on the registered daily water consumption. The initial setting is 25% of the capacity, which will adjust over time to accurately reflect daily water use.
- If you prefer, you can select a Fixed Reserve. While at the Reserve screen when "variable" is flashing, press the UP OR DOWN ARROW.

The control will display:

Rsrv: 200 GL Fxd

- To adjust the reserve, press the SCROLL BUTTON. Use the UP OR DOWN ARROW to set the reserve capacity in increments of 10 gallons, up to 70% capacity of the bed.
- To calculate the reserve capacity, take the number of people in the home and multiply it by 70 gallons per day. The reserve capacity will equal one day of water use.

**Example: 3 people X 70 gallons per day = 210 gallons (suggested reserve capacity)**

**Press the SCROLL BUTTON to advance to the next setting.**

### 3. TIME OF REGENERATION

The control will display:

Regen @ 2:00 am

- Press the UP or DOWN ARROW to adjust the time of regeneration.

Regeneration should be set for a time when water use is minimal. 2:00 AM is good for most households.



#### Notice

**The system diverts hard water to the home during regeneration. If any water is drawn during regeneration, some hard water will enter the plumbing system and possibly the hot water tank. Keep in mind that the regeneration cycle can last up to two hours after the starting time.**

**Press the SCROLL BUTTON to advance to the next setting.**



## ADVANCED MENU CONTINUED

---

### 4. DAYS OVERRIDE

The control will display:

Override: OFF

- Press the UP or DOWN ARROW to set the number of days between regenerations. The setting range is OFF to 30 days.



#### Notice

In most situations with a meter equipped valve, override can remain "OFF". Set a number of days if you wish to have the system regenerated periodically regardless of water use.

Press the SCROLL BUTTON to advance to the next setting.

### 5. CYCLE 1 - BACKWASH

The control will display:

Backwash: 10 min

- Press the UP or DOWN ARROW to change the length of the backwash cycle. The setting range is 5 to 99 minutes. We do not recommend a backwash of less than 10 minutes.

Press the SCROLL BUTTON to advance to the next setting.

### 6. CYCLE 2 - BRINE/SLOW RINSE

The control will display:

BRN/RNS: 74 min

Press the Up or Down ARROW to change the length of the brine/slow rinse cycle. The minimum length is preselected based on unit size and salt level, and cannot be reduced. The maximum setting is 99 minutes.

Press Down Arrow to exit Installer's Mode.

To Exit Press Down Arrow



#### Notice

**IMPORTANT NOTE: TO ACTIVATE THE NEW SETTINGS, YOU MUST EXECUTE A COMPLETE REGENERATION. IF YOU DO NOT MANUALLY REGENERATE THE SYSTEM, THE SETTINGS WILL NOT BECOME ACTIVE UNTIL THE UNIT HAS COMPLETED THE NEXT SCHEDULED REGENERATION.**

## HOW TO PROGRAM THE END USER'S LEVEL

---

To begin, verify that the control is in the Service Mode:

Time of Day GL Remaining

**Press the SCROLL BUTTON to advance to the next setting.**

The following settings are available in the End User's Level:

### 1. TIME OF DAY

The control will display:

Set Time of Day

- Press the UP or DOWN ARROW to program the time of day.

**Press the SCROLL BUTTON to advance to the next setting.**

### 2. IMMEDIATE REGENERATION MODE

The control will display:

Regen in 10 sec

- If the control is left in this position, the timer will countdown from 10 to 0, initiating a regeneration at 0.
- To avoid an immediate regeneration, press the SCROLL BUTTON before the timer reaches 0.

**Press the SCROLL BUTTON to advance to the next setting.**

### 3. DELAYED REGENERATION MODE

The control will display:

Regen @ (2.00 am)

- If the control is left in this position, the unit will regenerate at the programmed time. The display will remain in the Delayed Regeneration Mode until the regeneration has begun.
- To cancel the Delayed Regeneration Mode, press the SCROLL BUTTON.

**Press the SCROLL BUTTON to return to the Service Mode.**

## UNDERSTANDING THE DIAGNOSTIC LEVEL

---

To begin, verify that the control is in the Service Mode.

Time of Day GL Remaining

- Press the UP ARROW and hold it for 5 seconds; the control will display:

Regen \_ Days Ago

The control is now in the Diagnostic Level. Use the SCROLL BUTTON to advance to each diagnostic. If no button is pressed within 5 minutes, the display will return to the Service Mode.

The following items are available in the Diagnostic Level (Read Only):

- **Regen \_ Days Ago:** Displays how many days ago the unit last regenerated.
- **In Srvc:** Displays how many days the control has been in service.
- **# of Regens:** Displays the number of regenerations that have taken place since the control was first installed.
- **Tot Vol:** Displays the total volume of water used since installation.
- **Last Rgn @:** Displays the amount of water used before the last regeneration.
- **Flow Rate:** Displays the current flow rate.
- **Avg Vol:** Displays the average daily water consumption.
- **Water Hard:** Displays the amount of hardness programmed into the control.
- **Rsrv:** Displays whether the control is programmed for a Fixed or Variable Reserve.
- **Regen @:** Displays the time of day the unit will regenerate.
- **Override:** Displays the override mode by reading "OFF" or the number of days programmed into the control.
- **Backwash:** Displays the minutes of backwash programmed into the control.
- **BRN/RNS:** Displays the minutes of brine and slow rinse programmed into the control.
- **FILL/RNS:** Displays the minutes of fast rinse and brine refill programmed into the control. This is calculated based on unit size and salt level, and is not settable by the user.
- **Units:** English - US
- **Salt Level:** Displays the amount of salt ( Low, Medium, or High) for regeneration.
- **M P Resets:** Displays how many times the control has lost power.
- **Memory Reset:** Displays how many times the control lost power long enough to lose the time of day.
- **SP1Sc PlumbR20:** Displays the current program.

To exit the Diagnostic Level, press the DOWN ARROW at the EXIT display.

## SANITIZING THE SOFTENER

---



### Notice

**The unit may be sanitized with or without salt in the brine tank.**

After the installation is complete, the following procedure can be used to sanitize the water conditioner:

1. Mix a 3/4 cup of common (unscented) 5.25% household bleach with 1 quart of water. Pour this solution into the brine well.



### Notice

**Do not pour undiluted bleach into the water conditioner.**

2. Initiate a manual regeneration. The solution will be drawn into the water conditioner during the regeneration process.
3. When the regeneration is complete, the water conditioner has been sanitized.

# VALVE EXPLODED VIEW

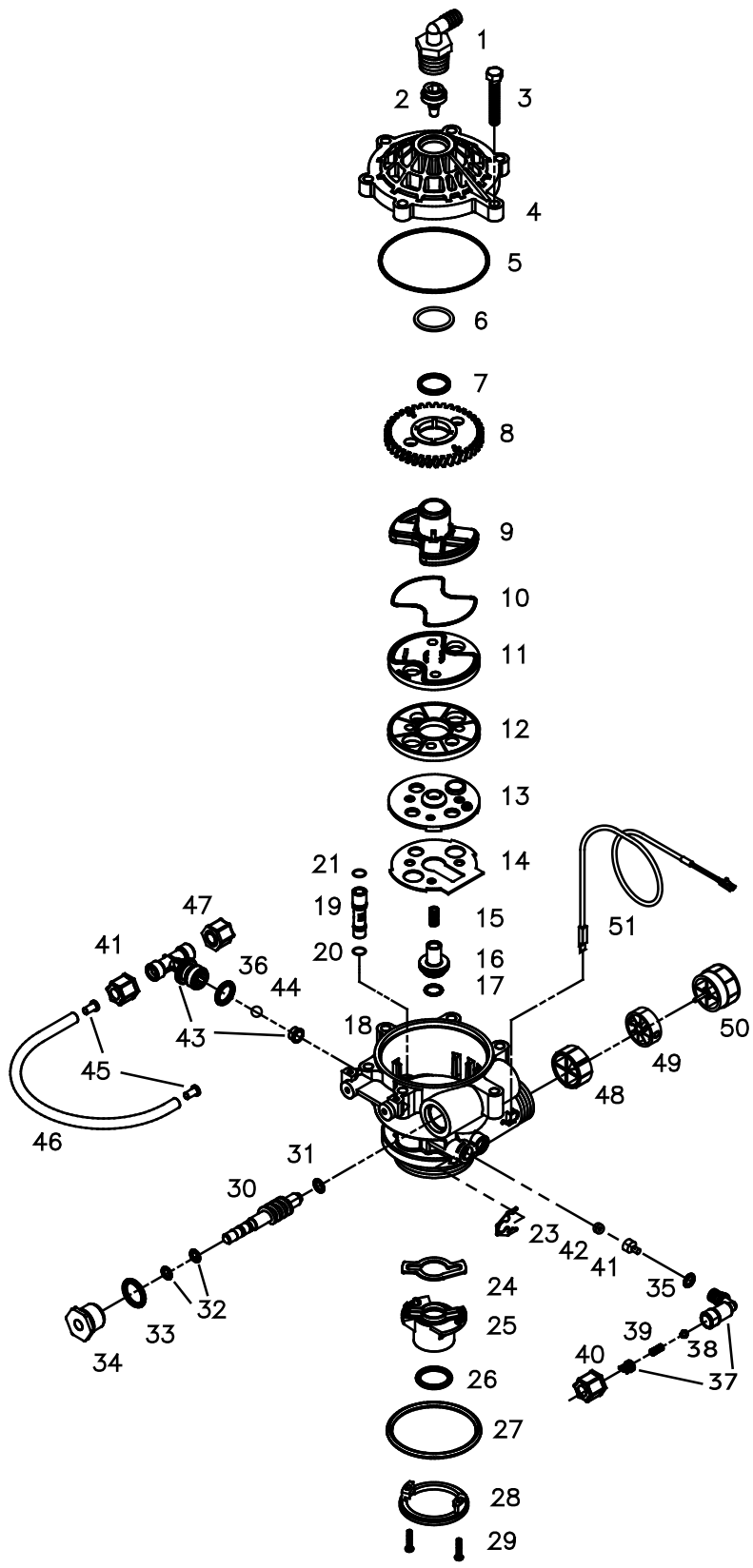

## VALVE PARTS LIST

ITEM	QUANTITY	PART #	DESCRIPTION
1	1	70793	3/4" NPTF TO 1/2" I.D. HOSE MALE DRAIN ELBOW
2	1	75053 72175	BACKWASH FLOW CONTROL 2.5 GPM (UNIT SIZE 1.0 & 1.5) BACKWASH FLOW CONTROL 3.5 GPM (UNIT SIZE 2.0)
3	6	72678	SCREW 1/4-20 X 1-1/4 LG HEX WASHER HD
4	1	71083	VALVE BODY COVER
5	1	70658	VALVE COVER O-RING
6	1	72327	WASHER
7	1	70665	TEFLON O-RING
8	1	71089	WORM GEAR
9	1	71087	CAM SHAFT
10	1	70656	ROTOR O-RING
11	1	71132	ROTOR PLATE
12	1	71084	SEAL DISK
13	1	71182	INSERT PLATE
14	1	71183	GASKET
15	1	71006	FLOAT VALVE SPRING
16	1	71127	FLOAT VALVE
17	1	70660	FLOAT VALVE O-RING
18	1	72770	VALVE BODY ROTARY GEN-3 W/INSERTS
19	1	71063 71064	INJECTOR #1 (UNIT SIZE 1.0 & 1.5) RED INJECTOR #2 (UNIT SIZE 2.0) YELLOW
20	1	70655	INJECTOR O-RING LOWER
21	1	70664	INJECTOR O-RING UPPER
23	1	71947	SPRING CLIP
24	1	71344	RISER INSERT GASKET
25	1	71118	RISER INSERT
26	1	70662	RISER TUBE O-RING
27	1	70663	TANK O-RING
28	1	71010	ADAPTER RING
29	2	71512	SCREW 6-20 X 21/32 LG SS
30	1	71060	WORM DRIVE SHAFT
31	1	70616	WORM DRIVE SHAFT WASHER
32	2	70666	WORM DRIVE SHAFT O-RING
33	1	70661	PACKING GLAND O-RING
34	1	72772	PLASTIC PACKING GLAND ROTARY
35	1	70667	O-RING
36	1	70659	O-RING
37	1	71124	BRINE REFILL ELBOW
38	1	71961	REFILL ELBOW CHECK BALL 1/4" DIA
39	1	70984	REFILL ELBOW SPRING
40	2	70797	COMPRESSION NUT FOR 3/8" TUBE JACO
41	1	71184	BRINE REFILL FLOW CONTROL
42	1	70994 70995	FLOW CONTROL WASHER 0.5 GPM (UNIT SIZE 1.0 & 1.5) FLOW CONTROL WASHER 1.0GPM (UNIT SIZE 2.0)
43	1	71129	BRINE TEE
44	1	70871	BRINE TEE CHECK BALL 3/8" DIA
45	2	12625	3/8" TUBE SUPPORT
46	1	13604	BRINE REFILL TUBE 3/8" O.D.X. 250" I.D. X 12" L
47	1	70797	COMPRESSION NUT FOR 3/8" TUBE JACO PG-6
48	1	72458	FLOW DIFFUSER
49	1	72544	IMPELLER ASSEMBLY WITH BUSHING
50	1	72545	HUB FLOW METER ASSEMBLY
51	1	72519	FLOW METER SENSOR CABLE 20"

**CONTROL EXPLODED VIEW**

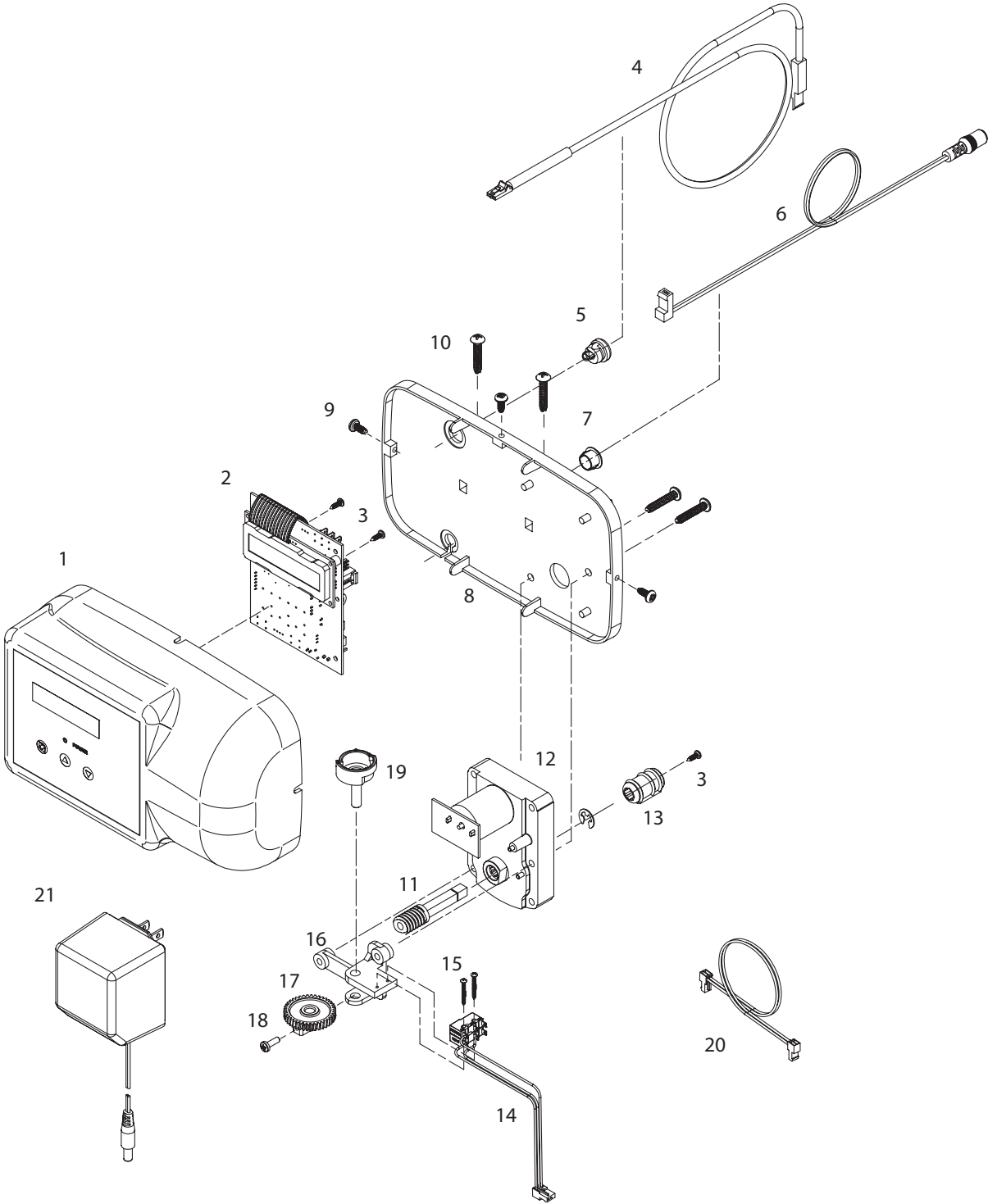

## CONTROL PARTS LIST

ITEM	QUANTITY	PART #	DESCRIPTION
1	1	39497	FRONT COVER ASSY, PENTAIR ROTARY
2	1	38751	BOARD ASSY SOFTENER WITH 2 LINE DISPLAY
3	3	70618	SCREW #4-24 X 3/8 LG SELF-THREADING
4	1	72519	FLOW METER SENSOR CABLE NGC
5	1	72134	HEYCO BUSHING, SR 5P-4
6	1	70971	POWER LEAD
7	1	70312	HEYCO BUSHING, SR 2P-4
8	1	70962	ELECTRONIC CONTROL BACKPLATE
9	3	71502	SCREW #8-18 X 3/8 LG, SELF-THREADING
10	4	71497	SCREW #10-16 X 1 LG, TYPE BT SS, SELF-THREADING
11	1	75156	ROTARY WORM DRIVE GEAR
12	1	71656	MOTOR, 24VCD WITH INTERNAL CAPACITORS
13	1	75157	ROTARY WORM COUPLING
14	1	72451	MICROSWITCHES SUBASSY 2401
15	2	70622	SCREW #2-28 X 3/4 LG, SELF-THREADING
16	1	71185	BRACKET
17	1	71106	HUB AND GEAR
18	1	70625	SCREW #6-32 X 7/16 LG
19	1	70965	CAM SHAFT
20	1	71679	MOTOR LEAD
21	1	72138	TRANSFORMER 120VAC .5 A



## BYPASS VALVE EXPLODED VIEW AND PARTS LIST

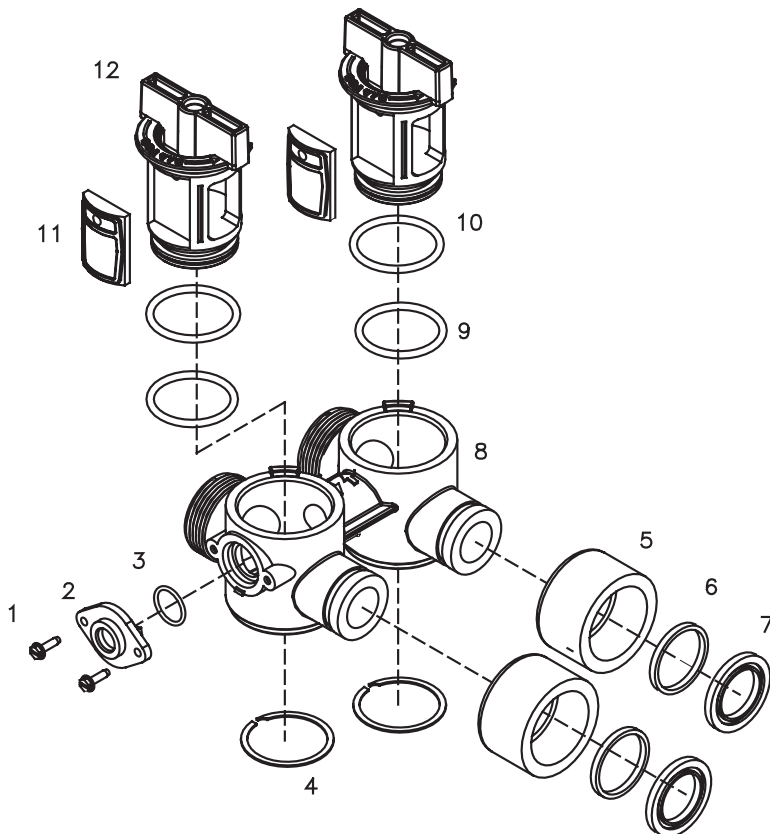

### BYPASS VALVE ASSEMBLY PART NUMBER 72668

ITEM	QUANTITY	PART #	DESCRIPTION
1	2	72599	SCREW 6X32X1/2 TYPE
2	1	72580	BYPASS END CAP 541
3	1	13328	017 O-RING 8730
4	2	72584	RETAINING RING VS-15
5	2	71161	568-363 NUT, BYPASS VALVE
6	2	71162	568-364 RING, NUT RETAINER
7	2	71110	568-320 GASKET
8	1	72669	BYPASS BODY ROTARY
9	2	72585	O-RING 220 EPC 70 DURO
10	2	72586	O-RING 222 EPC 70 DURO
11	2	72583	SEAL BYPASS VALVE
12	2	72670	BYPASS HANDLE ROTARY

# SYSTEM EXPLODED VIEW AND PARTS LIST

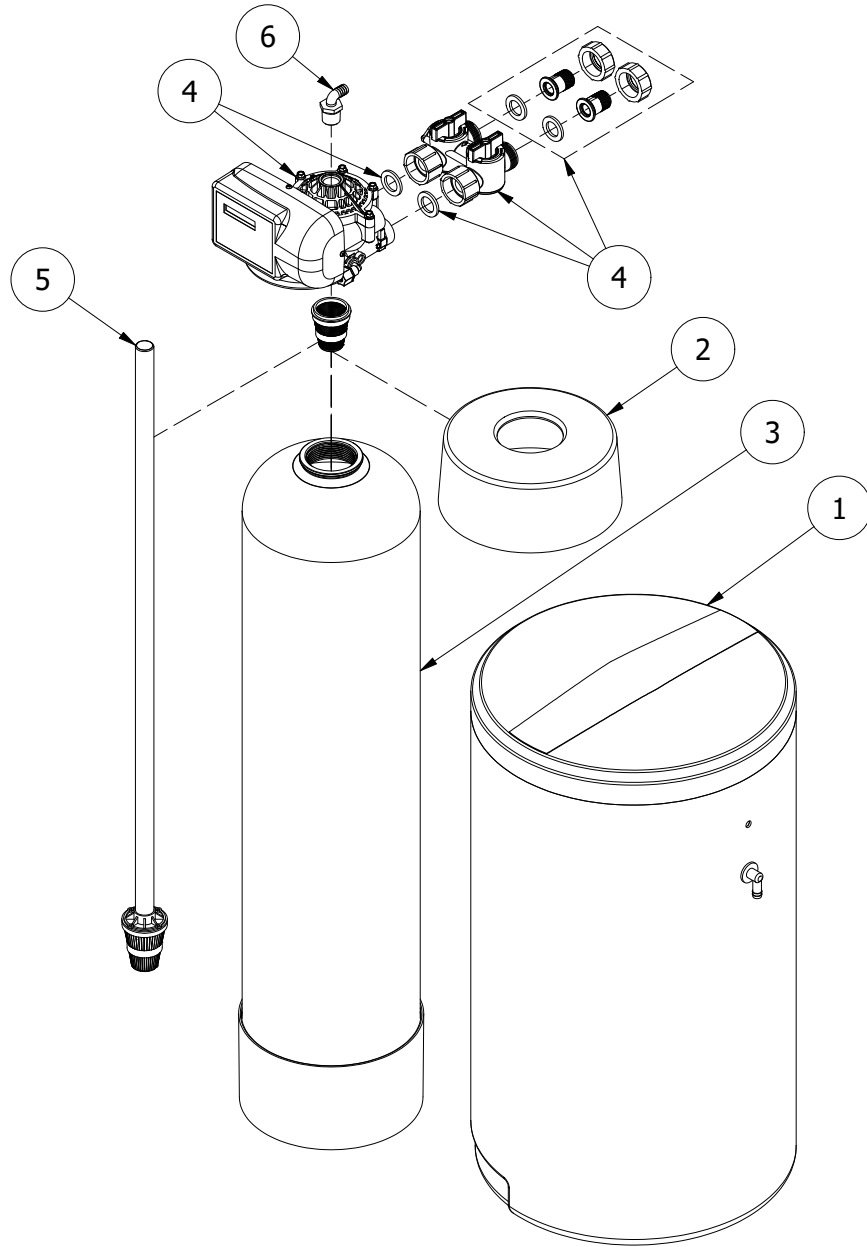

ITEM	QUANTITY	PART #	DESCRIPTION
1	1	38571	BRINE TANK BLACK 18X33 ASSY
2	1	38946	10" PENTAIR PRINTED TANK COLLAR 1.0 & 1.5
		38947	12" PENTAIR PRINTED TANK COLLAR 2.0
3	1	38256	10 X 44 TANK BLACK W/BASE 1.0
		38257	10 X 54 TANK BLACK W/BASE 1.5
		38258	12 X 48 TANK BLACK W/BASE 2.0
4	1	83487	PENTAIR ROTARY VALVE 1.0 & 1.5 WITH BYPASS
		83488	PENTAIR ROTARY VALVE 2.0 WITH BYPASS
5	1	18961	RISER PIPE ASSY 1.0
		18962	RISER PIPE ASSY 1.5
		38013	RISER PIPE ASSY 2.0
6	1	70793	3/4" NPT TO 1/2 ID ELBOW

Tank Size	DIM A	DIM B	DIM C
10x44	10-1/4 in	46 in	51 in
10x54	10-1/4 in	55-7/8 in	61-1/4 in
12x48	12 in	50 in	55-1/4 in

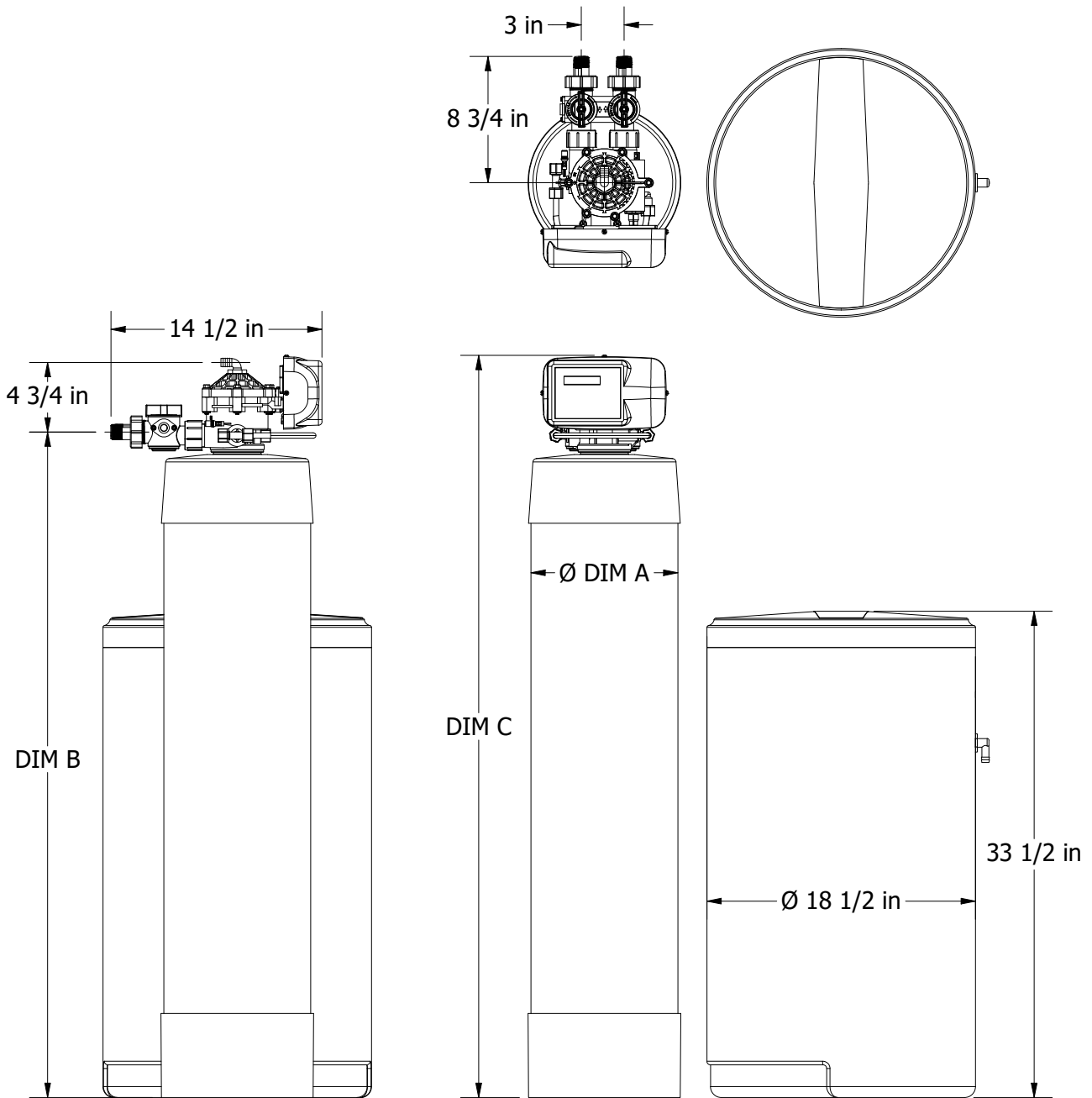

## TROUBLESHOOTING GUIDE

SYMPTOM	CAUSE	SOLUTION
<p>1. Hard (untreated) water to service</p>	<ol style="list-style-type: none"> <li>1. Open bypass valve.</li> <li>2. Loss of resin.</li> <li>3. The valve is in regeneration.</li> <li>4. Excessive water use.</li> <li>5. Change in raw water hardness.</li> <li>6. The unit fails to regenerate.</li> <li>7. The valve fails to draw brine.</li> <li>8. Decreasing exchange capacity of resin.</li> <li>9. No salt in the brine tank.</li> <li>10. Leak between rotor and seal disk.</li> <li>11. Leak at the riser tube.</li> <li>12. The valve body and timer are out of synchronization.</li> </ol>	<ol style="list-style-type: none"> <li>1. Close the bypass valve.</li> <li>2. Refer to SYMPTOM #9.</li> <li>3. Wait for the regeneration to complete.</li> <li>4. Check the frequency of regenerations.</li> <li>5. Adjust settings accordingly.</li> <li>6. Refer to SYMPTOM #2.</li> <li>7. Refer to SYMPTOM #3.</li> <li>8. Clean or replace the resin bed.</li> <li>9. Add salt to the brine tank.</li> <li>10. Check the rotor and seal disk; replace if necessary.</li> <li>11. Verify that the riser tube is seated correctly and is not cracked.</li> <li>12. Synchronize the valve body and timer.</li> </ol>
<p>2. The unit fails to regenerate</p>	<ol style="list-style-type: none"> <li>1. Faulty electrical supply.</li> <li>2. The control is not set properly.</li> <li>3. The drive motor is defective.</li> <li>4. The flow meter is defective.</li> <li>5. The computer board is defective.</li> <li>6. The microswitches are defective.</li> </ol>	<ol style="list-style-type: none"> <li>1. Check the electrical items (fuse, transformer).</li> <li>2. Verify the correct regeneration schedule and reset the control.</li> <li>3. Replace the drive motor.</li> <li>4. Replace the flow meter.</li> <li>5. Replace the computer board.</li> <li>6. Replace the microswitches.</li> </ol>

If the troubleshooting guide did not resolve the unit's symptoms, please contact your local Dealer for service.

## TROUBLESHOOTING GUIDE CONTINUED

SYMPTOM	CAUSE	SOLUTION
<p>3. The valve fails to draw brine</p>	<ol style="list-style-type: none"> <li>1. Low operating pressure.</li> <li>2. The injector is plugged.</li> <li>3. The injector filter is plugged.</li> <li>4. The drain line is restricted.</li> <li>5. The brine line is restricted.</li> <li>6. Leak in the brine line.</li> <li>7. Not enough water in the brine tank.</li> </ol>	<ol style="list-style-type: none"> <li>1. Verify the operating pressure (20 psi min.).</li> <li>2. Clean the injector.</li> <li>3. Clean the injector filter.</li> <li>4. Check the drain line for kinks or restrictions. Verify that the backwash flow control is free of debris.</li> <li>5. Check the brine line for kinks or restrictions.</li> <li>6. Check the brine line and connections for leaks.</li> <li>7. Refer to SYMPTOM #6.</li> </ol>
<p>4. The valve cycles continuously</p>	<ol style="list-style-type: none"> <li>1. Defective or shorted microswitch(es).</li> </ol>	<ol style="list-style-type: none"> <li>1. Replace the microswitch(es).</li> </ol>
<p>5. Excessive water in the brine tank</p>	<ol style="list-style-type: none"> <li>1. The valve fails to draw brine.</li> <li>2. Improper or missing brine refill flow control.</li> <li>3. Leak between the rotor and seal disk.</li> </ol>	<ol style="list-style-type: none"> <li>1. Refer to SYMPTOM #3.</li> <li>2. Verify that the flow control is installed and properly sized.</li> <li>3. Check the rotor and seal disk; replace if necessary.</li> </ol>
<p>6. The valve fails to refill the brine tank</p>	<ol style="list-style-type: none"> <li>1. Blockage in the brine line or brine valve.</li> <li>2. Improper or missing brine refill flow control.</li> <li>3. Plugged brine refill flow control.</li> </ol>	<ol style="list-style-type: none"> <li>1. Remove the blockage.</li> <li>2. Verify that the flow control is installed and properly sized.</li> <li>3. Remove the debris.</li> </ol>

If the troubleshooting guide did not resolve the unit's symptoms, please contact your local Dealer for service.

## TROUBLESHOOTING GUIDE CONTINUED

SYMPTOM	CAUSE	SOLUTION
7. The unit uses too much salt	<ol style="list-style-type: none"> <li>1. Excessive water in the brine tank.</li> <li>2. The unit regenerates too frequently.</li> </ol>	<ol style="list-style-type: none"> <li>1. Refer to SYMPTOM #5.</li> <li>2. Check the hardness, salt, reserve capacity and calendar override settings.</li> </ol>
8. Salt water to service	<ol style="list-style-type: none"> <li>1. Excessive water in the brine tank.</li> <li>2. Low water pressure.</li> </ol>	<ol style="list-style-type: none"> <li>1. Refer to SYMPTOM #5.</li> <li>2. Check the injector size and increase the brine/slow rinse time.</li> </ol>
9. Loss of resin through the drain line	<ol style="list-style-type: none"> <li>1. Excessive backwash/fast rinse flow.</li> <li>2. The lower and/or upper distributor is damaged.</li> <li>3. A leak between the riser tube and upper distributor.</li> </ol>	<ol style="list-style-type: none"> <li>1. Verify that the backwash flow control is installed and sized correctly.</li> <li>2. Replace the distributor(s).</li> <li>3. Verify that the riser tube is seated correctly and is not cracked.</li> </ol>
10. Loss of water pressure	<ol style="list-style-type: none"> <li>1. Mineral or iron build up in the resin tank.</li> <li>2. Plugged lower and/or upper distributor.</li> <li>3. Crushed lower and/or upper distributor.</li> <li>4. Plugged the riser pipe.</li> </ol>	<ol style="list-style-type: none"> <li>1. Clean the resin bed and control valve. Increase the regeneration frequency.</li> <li>2. Remove the debris from the distributor(s).</li> <li>3. Replace the distributor(s).</li> <li>4. Remove and clean the riser pipe.</li> </ol>
11. Constant water flow to the drain	<ol style="list-style-type: none"> <li>1. Drive motor failure.</li> <li>2. Computer board failure.</li> <li>3. Defective microswitch(es).</li> <li>4. The valve body and timer are out of synchronization.</li> </ol>	<ol style="list-style-type: none"> <li>1. Replace the drive motor.</li> <li>2. Replace the computer board.</li> <li>3. Replace the microswitch(es).</li> <li>4. Synchronize the valve body and timer.</li> </ol>

If the troubleshooting guide did not resolve the unit's symptoms, please contact your local Dealer for service.

# PERFORMANCE DATA SHEET

## Pentair Whole House Water Softening System

Model	Pentair Water Softening System 1.0	Pentair Water Softening System 1.5	Pentair Water Softening System 2.0
Rated Service Flow (gpm)	10.0	11.8	14.5
Pressure Drop at Rated Service Flow Rate (psi)	9.0	15	15
Rated Capacity (grains @ lb of salt)	16,660 @3.9 lbs of salt 24,593 @7.9 lbs of salt 30,726 @15.8 lbs of salt	24,990 @5.8 lbs of salt 36,889 @11.8 lbs of salt 46,089 @23.7 lbs of salt	33,332 @7.8 lbs of salt 49,186 @15.8 lbs of salt 61,452 @31.6 lbs of salt
Rated Efficiency (grains/lb Salt @ lb of salt)	4272@3.9 lb of salt	4272@5.8 lb of salt	4272@7.8lb of salt
Ion Exchange Resin (cu ft)	1.0	1.5	2.0
Tank Size	10x44	10x54	12x48
Drain Flow Rate (gpm)	2.5	2.5	3.5

Operating Pressure: 20 -120 psi (138 kPa - 828 kPa), Operating Temperature: 40 - 100° F (4.4° C - 38° C) Acceptable Salt Type: Sodium Chloride - Pellet or solar salt water softeners

All Systems tested at 35psi +/- 5 psi, pH of 7.5 +/- 0.5, Capacity Testing Flow Rate = 50% of the rated service flow rate for the various size systems.

These water softener systems have been tested by WQA and conform to NSF/ANSI 44 for specific performance claims as verified and substantiated by test data. The rated salt efficiencies above were also determined in accordance with NSF/ANSI 44 and are only valid at the salt dosage referenced above. An efficiency rated water softener is a demand initiated regeneration (DIR) softener which also complies with specific performance specifications intended to minimize the amount of regenerant brine and water used in its operation. Efficiency rated water softeners shall have a rated salt efficiency of not less that 3350 grains of total hardness exchanged per pound of salt (based on NaCl equivalency)(477 grams of total hardness exchanged per kilogram of salt), and shall not deliver more salt than its listed rating. The rated efficiency of the water softener, the salt dosage at that efficiency, the capacity at that salt dosage and that of the efficiency is only valid at the stated salt dosage. Efficiency is measured by a laboratory test described in NSF/ANSI 44. The test represents the maximum possible efficiency the system can achieve. Operational efficiency is the actual efficiency achieved after the system has been installed. It is typically less than the stated efficiency due to individual application factors including water hardness, water usage, and other contaminants that reduce the water softener's capacity. These systems are not intended to be used for treating water that is microbiologically unsafe or of unknown quality without adequate disinfection before or after the system.

Refer to the Owner's Manuals for set-up and programming instructions. See owner's manual for warranty information.



Tested and Certified by WQA against NSF/ANSI Std. 44 for softener performance, 372 for "lead free" compliance & CSA B483.1.

Pentair  
13845 BISHOPS DR., SUITE 200  
BROOKFIELD, WI 53005 USA

For Pentair Product Warranties visit: [pentair.com/assets/residential-filtration-warranty](https://pentair.com/assets/residential-filtration-warranty)



2361 Mason Ave. | Suite 100 | Daytona Beach, FL 32117 | United States  
P: 877.842.1635 | Technical Services: 877.842.1635 | [pentair.com](https://pentair.com)

© 2022 Pentair. All indicated Pentair trademarks and logos are property of Pentair. Third party registered and unregistered trademarks and logos are the property of their respective owners.

37297 REV E JE22