



AURORA[®]

MODEL 654A
**VERTICAL ONE STAGE
SOLIDS HANDLING PUMP**
INSTRUCTION AND REPAIR MANUAL

NOTE! To the installer: Please make sure you provide this manual to the owner of the equipment or to the responsible party who maintains the system.

THIS PAGE INTENTIONALLY LEFT BLANK

CALIFORNIA PROPOSITION 65 WARNING:

▲ WARNING This product and related accessories contain chemicals known to the State of California to cause cancer, birth defects or other reproductive harm.

SERVICE

Your Aurora pump requires no maintenance other than periodic inspection, occasional cleaning and lubrication of bearings. The intent of inspection is to prevent breakdown, thus obtaining optimum service life. The liquid end of the pump is lubricated by the fluid being pumped and therefore does not require periodic lubrication. The motor, however, may require lubrication, in which case, the motor manufacturer's recommendations should be followed.

REPAIRS

The pump may be disassembled using the illustrations and text provided. Although complete disassembly is covered, it will seldom be necessary to completely disassemble your Aurora pump.

The illustration accompanying the disassembly instructions shows an exploded view of the pump. The illustration is intended to aid in the correct identification of the parts mentioned in the text.

Inspect removed parts at disassembly to determine their reusability. Cracked castings should never be reused. Gaskets should be replaced at reassembly simply as a matter of economy; they are much less expensive to replace routinely than to replace as the need occurs. In general, it is economical to return the motor and motor controller to the manufacturer for repair.

PUMP MODEL 654A DISASSEMBLY (Motor Frame 250 or Smaller)

This pump has been designed with back pull-out features, which allow the power frame and rotating element to be removed without disturbing the suction and discharge piping.

Disassemble only what is needed to make repairs or accomplish inspection.

1. Break electrical connections to prevent drive unit from being energized during disassembly.

2. Close all valves or flow devices that control movement of liquids to or from pump. Remove drain plug (70) from suction elbow (65).

3. Remove all relief, cooling, flushing or drain lines from pump. Remove handhole cover (19) by removing capscrews (20), nuts (20A), washers (20B) and gasket (18). Break suction and discharge connections, unless the intention is to remove the entire motor and motor bracket assembly, and leave the casing (1) in the line.

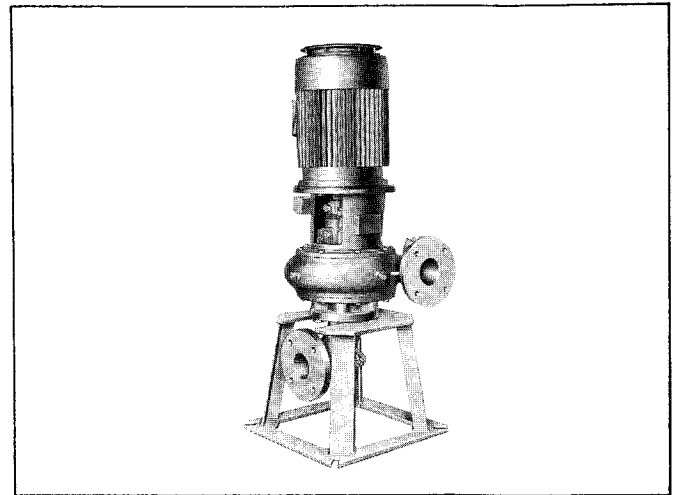

4. Unscrew capscrews (66B) to remove pump from base (21). The pump elbow (65) is removed by the loosening of capscrews (66). Gasket (64) may now be removed. If required, handhole cover (68) may be removed from elbow (65), by removing capscrews (69), nuts (69A), washers (69B) and gasket (67).

5. Remove capscrews (34) and slide casing (1) from bracket (8) and stuffing box (27). Remove gasket (17). Should suction cover (5) need to be removed, unscrew capscrews (15) and remove gasket (16).

6. Unscrew impeller screw (10) and remove o-ring gasket (11) and washer (12), taking care not to damage gasket (13).

NOTE

650A Pumps have a tapered shank impeller to facilitate impeller removal. Use caution in the removal of impeller, as it has to be moved only a few thousandths of an inch to become entirely free.

7. Slide impeller (2) and impeller key (14) from the shaft, again taking care not to damage gasket (38) located behind impeller. Remove gasket (38).

8. The various types of stuffing boxes may be disassembled as follows:

MECHANICAL SEAL (STANDARD)



The mechanical seal is a precision product and must be treated as such. During removal great care must be taken to avoid dropping any part of the seal. Take

particular care not to scratch the lapped faces on the washer or the sealing seat. Do not put a seal back into service until the sealing faces of the washer and seat have been lapped or replaced

A. Remove seal gland bolts (45) and remove gland (44) carefully exposing seal (47).

B. Unscrew capscrews (33), and remove stuffing box assembly (27). Remove gasket (32).

C. Slide sleeve (36) with rotating parts of mechanical seal (47) from the shaft. Remove ceramic seal rings and stainless steel parts from sleeve with great care as ceramic parts are easily damaged.

The sleeve should be carefully cleaned to remove any residue that may be remaining in the seal area, as the rubber in the seal may have become partially adhered to the sleeve. The sleeve must also be checked for abrasion or corrosion that can occur when fluid residue penetrates between the seal (47) and sleeve (36). The sleeve under the seal may be polished lightly to a 32 RMS finish before reassembly. Do not reuse a pitted sleeve. Remove retaining ring (37).

D. Remove stationary seats and o-rings from gland (44) and stuffing box (27), using care not to damage these parts.

PACKING WITH LANTERN RING (OPTIONAL)

A. Remove capscrews (45), and split accumulator gland halves (44). Remove o-ring gasket (42) from stuffing box.

B. Remove and discard old packing (40). Clean all parts to remove any packing that may have adhered. Leakage accumulator gland (44) may be further disassembled by removing capscrews (44A), pipe plugs (44D), tubing (44C) and hose connector (44B).

C. Unscrew capscrews (33) and remove stuffing box (27) from bracket (8). Remove gasket (32).

D. Shaft sleeve (36) is a slip fit on the shaft and should be easily removed unless the pump has been in service for a long time. In this case it may be necessary to use a puller. A snap ring may be installed in the sleeve groove to ease disassembly. Take care to prevent damaging the surface of the sleeve. Replace the sleeve if it is grooved from wear. Remove key (54) and retaining ring (37) from shaft.

9. Unscrew capscrews (35) to remove bracket (8) from close-coupled motor.

10. Remove screws (72) and nameplate (73) only if replacement is necessary.

REASSEMBLY PUMP MODEL 654A (Motor Frame 250 or Smaller)

Reassembly will generally be in reverse order of disassembly. If disassembly was not complete, use only those steps related to your particular repair program.

1. Position bracket (8) on the close coupled motor and secure with capscrews (35). Tighten capscrews evenly to assure proper alignment.

2. If name plate (73) was removed, install and attach with screws (72).

3. Reassemble the various types of stuffing boxes as follows:

MECHANICAL SEAL (STANDARD)

NOTE

The mechanical seal (47) cannot be installed as an assembly. It is necessary to have the seal seats properly in place before the balance of parts can be added.

A. Install retaining ring (37) and key (54) in shaft.

B. Wipe the sealing faces of the seat and seal washer clean. Lubricate the shaft sleeve (36) with a silicone-based lubricant. Slide the entire rotating assembly onto the sleeve.

C. Thoroughly inspect the seal box cavity checking for burrs or nicks that could damage the seat of the seal. Apply a film of liquid dishwashing detergent or rubber lubricant, (do not use oil or grease) to the seal seats. Replace stationary seats and o-rings in gland (44) and stuffing box (27).

NOTE

If it is not possible to insert seat with fingers, place cardboard protecting ring furnished with seal over lapped face of seat and press into place with a piece of tubing having an end cut square. The tubing should be slightly larger than the diameter of the shaft. Remove cardboard after seat is firmly in place. Carefully slip the stuffing box assembly (27) over the shaft sleeve with the stationary seat facing away from the motor. Install gasket (46) into gland (44).

Apply a film of liquid dishwashing detergent or rubber lubricant to the washer and bellows of the seal, and slide the remaining seal parts onto the shaft, making sure the washer is seated against the seal seat.

D. The shaft sleeve (36) with the seal rotating assembly on it may now be placed on the shaft. The shaft sleeve (36) should slide over shaft with keyway for key (54) toward close-coupled motor.

E. Replace gasket (32) on bracket (8) and carefully slip stuffing box (27) with stationary seal seat toward motor over the shaft and secure with capscrews (33).

F. Position gland (44) onto stuffing box (27) taking care to seat it evenly and squarely. Secure by tightening capscrews (45) evenly, being careful not to damage gasket (46) between them.

PACKING WITH LANTERN RING (OPTIONAL)

A. Place gasket (32) on stuffing box (27), slide over shaft and secure to bracket (8) with capscrews (33).

B. Install retaining ring (37), place key (54) in shaft and slide sleeve (36) over shaft. Packing (40) and lantern ring (41) may be replaced at this time. From impeller end of shaft, place two new rings of packing (40) around shaft sleeve, slide lantern ring (41) back in position and place remaining three rings of packing on shaft sleeve. Be sure to stagger joints of packing rings to avoid excessive leakage through the packing.

C. Place o-ring gasket (42) in stuffing box on top ring of packing (40). Be sure o-ring remains concentric against inside diameter of the stuffing box. Slide slinger (43) over shaft extension and adjust to $\frac{1}{4}$ in. below top of leakage accumulator after stuffing box assembly has been reattached to bracket. Replace pipe plugs (44D), hose connector (44B) and tubing (44C) in leakage accumulator glands (44). Place one half of leakage accumulator gland in stuffing box with connection for hose positioned to drain properly.

Apply General Electric* Silicon Rubber Sealant on both ends of this gland half. Thread capscrews (45) into stuffing box (27) approximately $\frac{1}{4}$ in. Insert other half of gland (44) in stuffing box being careful not to disturb o-ring gasket (42). Insert capscrews (44A) into each side of gland (44) to hold the two halves together. Tighten capscrews (44A) before tightening packing, adjusting capscrews (45A) to obtain proper sealing.

Ensure capscrews (45) are tightened enough to hold parts in place. Final adjustment of packing box will have to be made after pump is returned to operation.

When the pump is returned to service, additional care must be given the packing box to ensure proper packing life. It is necessary to allow 60 to 120 drops leakage per minute through the packing for lubrication purposes. If the flow rate is other than this, capscrews (45) should be either loosened or tightened one quarter turn at a time to acquire the correct leakage (capscrews must be turned equally to prevent cocking of the gland). It will take approximately ten minutes at any one gland setting before the leakage rate will stabilize. When in doubt, choose the greater leakage rate since overly tight packing will ruin not only the packing, but the sleeve as well.

4. Carefully place o-ring gasket (38) on shaft sleeve (36). Assemble key (14) and impeller (2) to shaft. Secure impeller with gasket (13), washer (12), o-ring gasket (11) and impeller screw (10). Torque impeller bolt to 75 ft. lbs.

5. Install pipe plugs (25) in the pump casing (1). Position gasket (17) and casing (1) against the bracket (8) and secure with capscrews (34).

6. Place casing gasket (16) on suction cover (5) and bolt to casing (1) with capscrews (15).

7. Place handhole cover gasket (18) on handhole cover (19) and bolt to casing (1) with capscrews (20), washers (20B) and nuts (20A). Replace all relief, cooling, flushing or drain lines from the pump. Place gasket (64) on elbow (65) and secure to pump. Pump may now be replaced on base (21) and secured

with capscrews (66B) and washers (66A). If handhole cover (68) was removed from elbow (65), replace using gasket (67), capscrews (69), washers (69B) and nuts (69A).

8. Secure suction and discharge piping to the pump. Make sure to install gaskets on flanged connections.

9. Connect electricity to the motor.

10. Open all valves or flow devices that control flow of liquids to and from pump.

STARTING PUMP AFTER REASSEMBLY

Do not start pump until all air and vapor have been bled, making sure that there is liquid in the pump to provide the necessary lubrication. Without the fluid around it, a seal may be ruined in a few seconds of operation. It is possible that the mechanical seal may drip during the first few minutes to one hour of operation.

Packing should be adjusted as previously discussed in this manual.

PUMP MODEL 654A DISASSEMBLY (Motor Frame 284 and Larger)

1. Disconnect power so that pump can not be accidentally energized during disassembly.

2. Close all valves or flow devices that control movement of liquids to or from pump. Drain pump by removing drain plug (70) from suction elbow (65). Remove any flushing, drain, or cooling lines from pump. Remove handhole cover (19) from casing by removing capscrews (20) and gasket (18).

3. Remove capscrews (34) that secure bracket (8) to casing (1). Screw an eyebolt into outboard end of the close-coupled motor or use sling under the motor lifting lugs to aid in lifting motor and rotating element from casing.

4. Remove gasket (17) from its position between bracket (8) and casing (1). Once the motor and rotating element have been withdrawn, inspect the sealing surface to ensure that it is clean and free of any gasket material which may have stuck to parting surfaces. Replace this gasket with a new one when pump is reassembled.

5. Inspect casing wearing ring (6) (optional) and replace if necessary. Removal can be accomplished by removing capscrews (7).

6. Remove capscrews (10), o-ring gasket (11), washer (12) and gasket (13), which allow impeller (2), key (14), and gasket (38) to be removed.

NOTE

Pumps have a tapered hub impeller to facilitate impeller removal. Use caution in removal of impeller as it has to be moved only a few thousandths of an inch to become entirely free.

7. Unscrew capscrews (35) to allow removal of bracket (8), stuffing box (27), and shaft sleeve (36) from the motor. Remove truarc snap ring (37) from the inboard end of the shaft sleeve (36). Lift bracket and stuffing box from shaft extension.

For further disassembly of sealing box proceed as follows:

A. Double Seal (Standard)

- I. Remove seal gland bolts (45) and remove gland (44) carefully exposing seal (47).
- II. Use great care in removing ceramic seal rings and stainless steel metal parts from sealing box, as ceramic parts are easily chipped or cracked.
- III. Remove carbon station seats and o-rings only if necessary, using care not to damage these parts.

B. Packing Box (Optional)

- I. Remove capscrews (45), and split accumulator gland halves (44). Slinger (43) is now exposed and can be removed from shaft sleeve. Remove o-ring gasket (42) from stuffing box.

Remove and discard old packing. Clean all parts to remove any packing that may have adhered during removal. Leakage accumulator gland (44), may be further disassembled by removing capscrews (44A), pipe plugs (44D), tubing (44C) and hose connectors (44B).

8. Place close-coupled motor on two benches, so that its shaft rests between them or on a bench with a hole cut in it large enough for shaft.

Remove retainer ring (37) by twisting it in a spiral movement toward end of shaft.

9. Pull shaft sleeve (36) from motor shaft using gear puller with jaws firmly secure behind sleeve.

10. If total disassembly is required, break connections to suction and discharge pipe and remove nuts from foundation bolts that hold support (21) to its foundation.

11. Secure casing and support assembly in sling and move it away from piping. Invert this assembly and set casing (1) on wood blocks, so as not to mar surface that mates with bracket (8).

12. Pipe plug or suction gage (71) can now be removed from suction elbow (65). Unscrew capscrews (69) and nuts (69A), and remove cover (68) and gasket (67) from suction elbow (65).

13. Place rope sling through elbow and cover opening. Remove capscrews (66) and lift suction elbow (65) away from cover (5). Remove gasket (64).

14. Unscrew capscrews (15) that hold support (21), cover (5) and casing (1) together. Lift support away and then set casing with discharge up. Gently tap cover loose with a rubber mallet. Remove gasket (16) to complete disassembly.

PUMP MODEL 654A REASSEMBLY
(Motor Frame 284 and Larger)

These instructions are for a pump that has been completely disassembled. Use those parts that apply to your reassembly program.

1. Place casing (1) with its outboard side down and position gasket (16) in place. Set cover (5) in place so the gasket position is neither lost nor damaged. Next align support (21) on cover. Use care not to disturb location of other parts. When all the above parts have been aligned, they are fastened together with capscrews (15). Tighten capscrews evenly to insure perfect register of mating parts. Replace pipe plugs (25) and (26) in casing.

2. Position gasket (64) on cover and carefully lower suction elbow (65) into place. Fasten suction elbow in place with capscrews (66).

3. Slip gasket (67) onto shoulder of cover (68) and secure it to suction elbow (65) with capscrews (69) and nuts (69A). Place plug or suction gage (71) and drain plug (70) back into suction elbow (65).

4. Return casing and support assembly to its normal position. Fasten suction and discharge piping to pump. Secure this assembly in place by tightening nuts on foundation bolts. If pump has wearing ring (6), fasten it to cover (5) with screws (7). If handhole cover (19) was removed, place gasket (18) on cover and secure with capscrews (20).

5. Retaining ring (37) can be set in its groove by turning it in a spiral motion up shaft. When in position, the outside diameter of this ring should slope toward impeller end of shaft.

6. Position bracket (8) to close-coupled motor and secure in place by evenly tightening capscrews (35).

7. The following procedure is used in assembling sealing box:

A. Double Seal Box (Standard)

I. Thoroughly inspect the seal box cavity (27) checking for burrs or nicks that could damage the O-ring of mechanical seal. Apply a film of liquid dishwashing detergent or rubber lubricant (do not use oil or grease) to the o-ring and seal seat. Press one stationary seat with o-ring gently into the seal box cavity and other into gland (44). Replace pipe plug (28) in seal box.

II. Place gasket (46) in position in the gland register.

III. Snap retainer ring (39) onto sleeve (36) with a pair of truarc number 8 or 10 external pliers.

IV. Slide sleeve through bottom of stuffing box and place one seal (47) over sleeve and slide it down to stationary seat. Place metal parts over shaft and then second seal ring.

V. Position gland (44) over shaft sleeve and fasten to seal box with capscrews (45).

NOTE

Do not put mechanical seal back into service until seal ring and stationary seat faces have been relapped or replaced.

B. Packing Box (Optional)

- I. Place two pieces of packing (40) into stuffing box cavity (27) being careful to get each piece firmly in place. Position lantern ring (41), then add remaining three pieces of packing. When packing is tightened lantern ring should align with holes for plug (29), flushing lines, or cooling lines.

NOTE

Be sure to stagger joints of packing rings to avoid excessive leakage.

- II. Replace bushing (29) and grease zerk (30) in body of stuffing box (27).
- III. Snap retaining ring (39) onto shaft sleeve (36) with a pair of truarc external snap ring pliers. Slide shaft sleeve carefully into inboard end of packing box.

- IV. Place o-ring gasket (42) in stuffing box on top ring of packing (40). Be sure o-ring remains concentric against inside diameter of the stuffing box. Slide slinger (43) over shaft extension and adjust to ¼ in. below top of leakage accumulator after stuffing box assembly has been reattached to bracket. Replace pipe plugs (44D), hose connector (44B) and tubing (44C) in leakage accumulator glands (44). Place one half of leakage accumulator gland in stuffing box with connection for hose positioned to drain properly. Apply General Electric* Silicon Rubber Sealant (75) on both ends of this gland half. Thread capscrews (45) into stuffing box (27) approximately ¼ in. Insert other half of gland (44) into stuffing box being careful not to disturb o-ring gasket (42). Insert capscrews (44A) into each side of gland (44) to hold the two halves together. Tighten capscrews (44A) before tightening packing adjusting cap-screws (45) to obtain proper sealing.

- V. Ensure capscrews (45) are tightened enough to hold parts in place. Final adjustment of packing box will have to be made after pump is returned to operation.

When pump is running, gland capscrews (45) should be evenly turned down a flat at a time, allowing packing to work in until a leakage rate of approximately 60 to 120 drops per minute is obtained.

NOTE

Do not over tighten packing, as this will cause packing box to over-heat and the shaft sleeve (36) to wear excessively.

- VI. Place gasket (38) in radial corner groove that is machined on the inboard end of the shaft sleeve to complete assembly.

- 8. Place gasket (32) in groove of bracket (8).

- 9. Place key (54) in its keyway on shaft. Slide stuffing box assembly onto shaft so that key and keyway in the shaft sleeve mate. Continue to slide assembly forward until shaft sleeve is in contact with retainer ring (37).

- 10. Align stuffing box (27) with gasket (32) and bracket (8). Fasten with capscrews (33).

- 11. If pump has impeller wearing ring (3), fasten it to suction end of impeller (2) with capscrews (4).

- 12. Place impeller key (14) in keyway on the tapered portion of motor shaft, and set impeller (2) in position. Position gasket (13) inside impeller suction eye with washer (12) next, and o-ring gasket (11) last. Secure impeller in place with capscrew (10).

IMPELLER BOLT TORQUE

Close Coupled Motor Register	Impeller Bolt Size	Torque Value
8½	¾ in.	75 FT-LBS
12½	¾ in.	100 FT-LBS

- 13. Place gasket (17) on casing (1) and lower close-coupled motor assembly into place; fasten this assembly to casing with capscrews (34).

- 14. Make one last check that all parts of the rotating element turn freely. If binding occurs, add additional shim gaskets (17) between bracket (8) and casing (1) to obtain clearance between impeller (2) and suction cover (5).

- 15. Connect any flushing lines or cooling lines that were removed.

- 16. Open all valves or flow devices that control flow of to and from pump.

- 17. Connect power.

NOTE

Do not start up a pump until all air and vapor have been bled, making sure that there is liquid in the pump to provide the necessary lubrication. It is possible that the mechanical seal may drip during the first few minutes of operation.

Turn on power momentarily to check for proper rotation. Rotation should be clockwise as viewed from driver (See arrow on casing).

*General Electric is a registered trademark of General Electric Corporation.

MODEL 654A LIST OF PARTS

1. Casing	27B. Split Packing Box	44C. Hose
2. Impeller	27C. Gasket	44D. Pipe Plug
3. Wear Ring	27D. Pin	45. Capscrew
4. Set Screw	27E. Capscrew	46. Gasket
5. Suction Cover	27F. Capscrew	47. Mechanical Seal
6. Wear Ring	28. Pipe Plug	47A. Bushing
7. Set Screw	29. Bushing	54. Sleeve Key
8. Bracket	30. Fitting	64. Gasket
10. Imp. Bolt	31. Pipe Plug	65. Suction Elbow
11. Imp. Bolt Seal	31A. Pipe Coupling	66. Capscrew
12. Imp. Washer	31B. Pipe Nipple	66A. Washer
13. Imp. Washer Gasket	32. Gasket	66B. Capscrew
14. Impeller Key	33. Capscrew	67. Gasket
15. Capscrew	34. Capscrew	68. Handhole Cover
16. Gasket	35. Capscrew	69. Capscrew
17. Gasket	36. Sleeve	69A. Nut
18. Gasket	37. Retaining Ring	69B. Washer
19. Handhole Cover	38. Gasket	70. Pipe Plug
20. Capscrew	39. Retaining Ring	71. Pipe Plug
20A. Nut	40. Packing	72. Drive Pins
20B. Washer	41. Lantern Ring	73. Name Plate
21. Pump Base	42. O-Ring	
25. Pipe Plug	43. Slinger	
26. Pipe Plug	44. Gland	
27. Stuffing Box	44A. Capscrew	
27A. Adapter Plate	44B. Hose Connector	

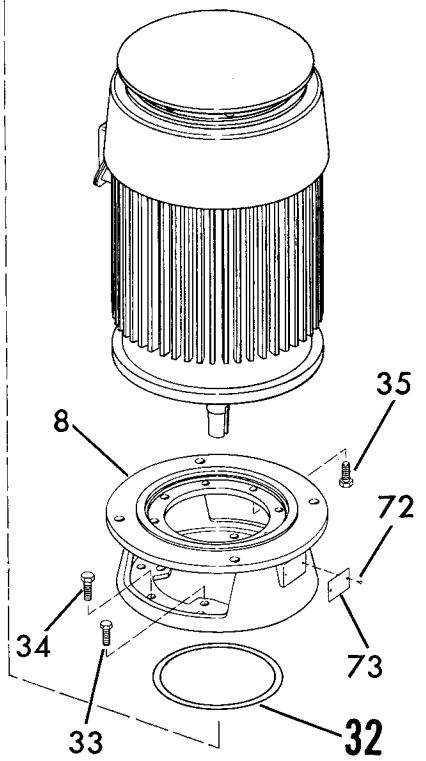
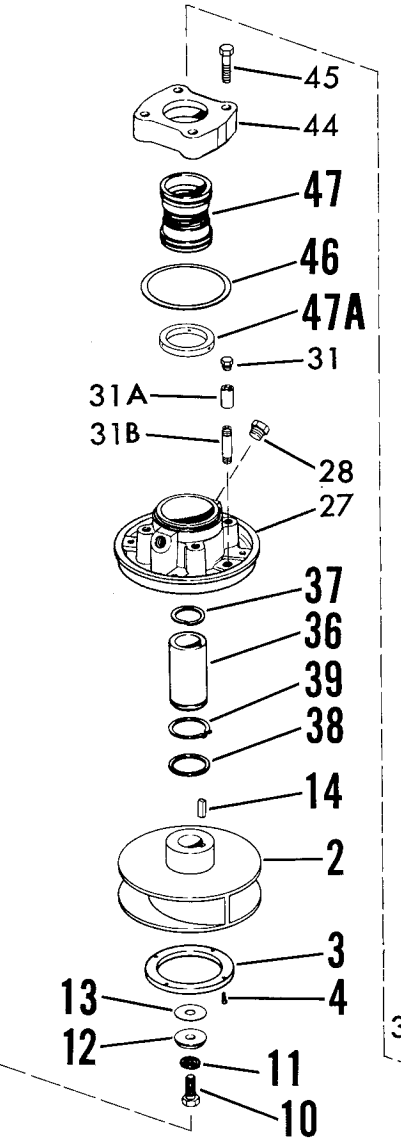
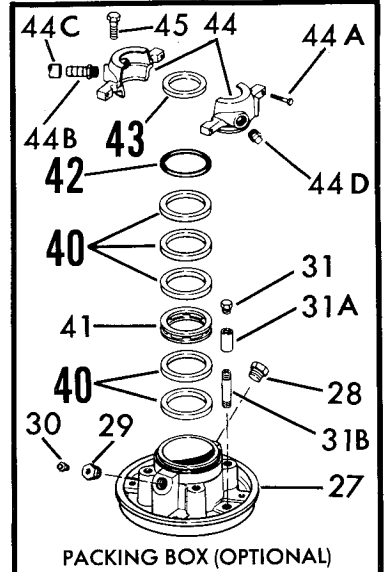
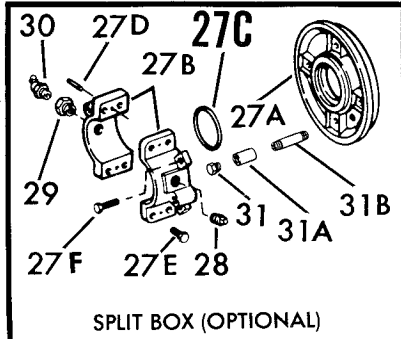
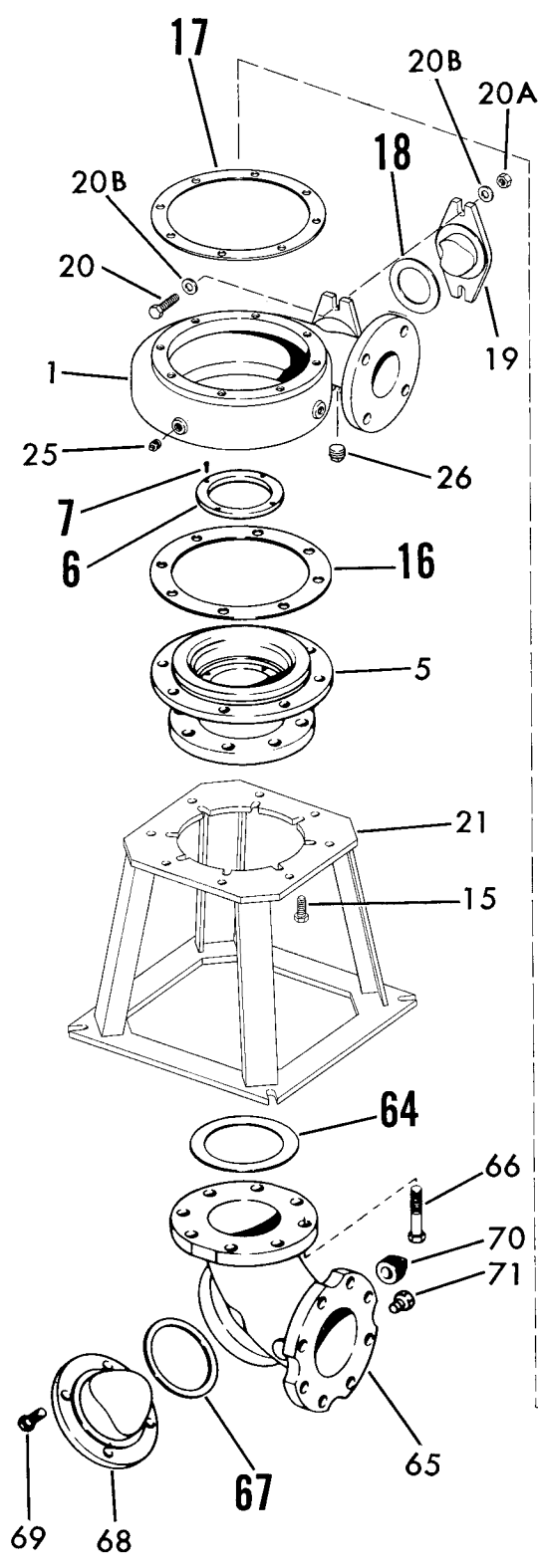

BOLD FACE NUMBERS INDICATE RECOMMENDED SPARE PARTS.

THIS PAGE INTENTIONALLY LEFT BLANK

THIS PAGE INTENTIONALLY LEFT BLANK

WARRANTY

Seller warrants equipment (and its component parts) of its own manufacture against defects in materials and workmanship under normal use and service for one (1) year from the date of installation or start-up, or for eighteen (18) months after the date of shipment, whichever occurs first. Seller does not warrant accessories or components that are not manufactured by Seller; however, to the extent possible, Seller agrees to assign to Buyer its rights under the original manufacturer's warranty, without recourse to Seller. Buyer must give Seller notice in writing of any alleged defect covered by this warranty (together with all identifying details, including the serial number, the type of equipment, and the date of purchase) within thirty (30) days of the discovery of such defect during the warranty period. No claim made more than 30 days after the expiration of the warranty period shall be valid. Guarantees of performance and warranties are based on the use of original equipment manufactured (OEM) replacement parts. Seller assumes no responsibility or liability if alterations, non-authorized design modifications and/or non-OEM replacement parts are incorporated. If requested by Seller, any equipment (or its component parts) must be promptly returned to Seller prior to any attempted repair, or sent to an authorized service station designated by Seller, and Buyer shall prepay all shipping expenses. Seller shall not be liable for any loss or damage to goods in transit, nor will any warranty claim be valid unless the returned goods are received intact and undamaged as a result of shipment. Repaired or replaced material returned to customer will be shipped F.O.B., Seller's factory. Seller will not give Buyer credit for parts or equipment returned to Seller, and will not accept delivery of any such parts or equipment, unless Buyer has obtained Seller's approval in writing. The warranty extends to repaired or replaced parts of Seller's manufacture for ninety (90) days or for the remainder of the original warranty period applicable to the equipment or parts being repaired or replaced, whichever is greater. This warranty applies to the repaired or replaced part and is not extended to the product or any other component of the product being repaired. Repair parts of its own manufacture sold after the original warranty period are warranted for a period of one (1) year from shipment against defects in materials and workmanship under normal use and service. This warranty applies to the replacement part only and is not extended to the product or any other component of the product being repaired. Seller may substitute new equipment or improve part(s) of any equipment judged defective without further liability. All repairs or services performed by Seller, which are not covered by this warranty, will be charged in accordance with Seller's standard prices then in effect.

THIS WARRANTY IS THE SOLE WARRANTY OF SELLER AND SELLER HEREBY EXPRESSLY DISCLAIMS AND BUYER WAIVES ALL OTHER WARRANTIES EXPRESSED, IMPLIED IN LAW OR IMPLIED IN FACT, INCLUDING ANY WARRANTIES OF MERCHANTABILITY OR FITNESS FOR A PARTICULAR PURPOSE. Seller's sole obligation under this warranty shall be, at its option, to repair or replace any equipment (or its component parts) which has a defect covered by this warranty, or to refund the purchase price of such equipment or part. Under the terms of this warranty, Seller shall not be liable for (a) consequential, collateral, special or liquidated losses or damages; (b) equipment conditions caused by normal wear and tear, abnormal conditions of use, accident, neglect, or misuse of said equipment; (c) the expense of, and loss or damage caused by, repairs or alterations made by anyone other than the Seller; (d) damage caused by abrasive materials, chemicals, scale deposits, corrosion, lightning, improper voltage, mishandling, or other similar conditions; (e) any loss, damage, or expense relating to or resulting from installation, removal or reinstallation of equipment; (f) any labor costs or charges incurred in repairing or replacing defective equipment or parts, including the cost of reinstalling parts that are repaired or replaced by Seller; (g) any expense of shipment of equipment or repaired or replacement parts; or (h) any other loss, damage or expense of any nature.

The above warranty shall not apply to any equipment which may be separately covered by any alternate or special warranties.

PERFORMANCE: In the absence of Certified Pump Performance Tests, equipment performance is not warranted or guaranteed. Performance curves and other information submitted to Buyer are approximate and no warranty or guarantee shall be deemed to arise as a result of such submittal. All testing shall be done in accordance with Seller's standard policy under Hydraulic Institute procedures.

LIABILITY LIMITATIONS: Under no circumstances shall the Seller have any liability under the Order or otherwise for liquidated damages or for collateral, consequential or special damages or for loss of profits, or for actual losses or for loss of production or progress of construction, regardless of the cause of such damages or losses. In any event, Seller's aggregate total liability under the Order or otherwise shall not exceed the contract price.

ACTS OF GOD: Seller shall in no event be liable for delays in delivery of the equipment or other failures to perform caused by fires, acts of God, strikes, labor difficulties, acts of governmental or military authorities, delays in transportation or procuring materials, or causes of any kind beyond Seller's control.

COMPLIANCE WITH LAW: Seller agrees to comply with all United States laws and regulations applicable to the manufacturing of the subject equipment. Such compliance shall include: The Fair Labor Standards Acts of 1938, as amended; Equal Employment Opportunity clauses of Executive Order 11246, as amended; Occupational Safety and Health Act of 1970 and the standards promulgated thereunder, if applicable. Since compliance with the various Federal, State, and Local laws and regulations concerning occupational health and safety, pollution or local codes are affected by the use, installation and operation of the equipment and other matters over which Seller has no control, Seller assumes no responsibility for compliance with those laws and regulations, whether by way of indemnity, warranty, or otherwise. It is incumbent upon the Buyer to specify equipment which complies with local codes and ordinances.



AURORA®

800 Airport Road
North Aurora, Illinois 60542
630-859-7000
www.aurorapump.com