

Model 383

# **AURORA**<sup>®</sup> 900 SERIES SINGLE STAGE INLINE FIRE PUMPS

Built Per  
NFPA 20



# AURORA® 900 SERIES

## Single Stage Inline Fire Pumps

Vertical inline close coupled fire pumps are specifically designed for vertical mounting. The suction and discharge nozzles are located on the same centerline 180° apart. Vertical pumps significantly reduce required mounting space. They are easy to maintain. Simply remove eight capscrews and the motor and bracket assembly are easily removed from the casing without disturbing the piping. The impeller is direct coupled to the motor shaft for easy maintenance, to minimize impeller run out and to reduce noise.

The inline casing is heavily ribbed to resist pipe strain and is provided with a support to simplify mounting to a base or foundation. Packing is provided when suction pressure is greater than 30 psig; packing with lantern ring and flush line is furnished for suction pressures of 30 psig or less. Look through this bulletin for additional details and specifications.

Back pull-out inline case design simplifies disassembly. The suction and discharge piping or alignment is not disturbed as the casing remains in the pipeline. Simply remove the motor and bracket assembly for service or inspection.

Computer machined major components with 360° registered fits assure parts concentricity.

### Superior Performance

- Flows from 50 to 1500 GPM (11 to 340 m<sup>3</sup>/hr)
- Pressures from 40 to 155 psi (2.8 to 10.7 bar) and beyond
- Pump design optimized for low hp requirements

### Accessories

- Suction and discharge pressure gauges
- Air release valve
- Circulation relief valve
- Hose valve header
- Hose valves
- Flow meter
- Jockey pump
- Optional flange drillings
  - 125 lb. suction – 250 lb. discharge
  - 250 lb. suction and discharge

### Standard

- Bronze fitted pump construction
- Bronze shaft sleeve
- Split bronze packing gland
- Carbon steel shaft
- 125# ANSI flange drilling
- Dynamically balanced vacuum cast impeller
- Stainless steel impeller screw and washer
- Bronze case wearing ring(s)
- Graphite impregnated acrylic packing
- Motor: NEMA-HI JP or TCZ frame
- Factory performance tested in accordance with NFPA-20

# Pump Features

- A. Back Pull-Out Casing**  
with inline suction and discharge.
- B. Case Wear Ring**  
prevents wear on casing and is easily and inexpensively replaced.
- C. Support**  
simplifies mounting. The pump can be fastened to the floor, a base or foundation.
- D. Dynamically Balanced Impeller**  
is keyed to the shaft and secured by a capscrew and washer. Vacuum casting and quality controlled manufacturing process assures consistent high performance. Enclosed design provides high efficiency and low wear for long service life.
- E. Carbon Steel Shaft**  
is designed for minimum deflection at maximum load.
- F. Two Piece Bronze Packing Gland**  
provides easy packing maintenance.
- G. Factory Performance Test**  
guarantees performance at specified pump operating conditions.
- H. Flush Line**  
with valve (when used) from discharge provides easy water seal adjustment to lantern ring.
- I. Bronze Shaft Sleeve**  
extends full length of stuffing box to protect motor shaft. The shaft sleeve is slip fit over the shaft and then is keylocked. Shaft sleeve and impeller screw are sealed by O-ring gaskets to eliminate corrosion of the shaft by the pumped liquid.
- J. Standard Motor**  
approved for 383 Series pump service by NEMA and the Hydraulic Institute provides low noise level pump operation.
- K. Volute Type Suction**  
inlet prerotates suction liquid.

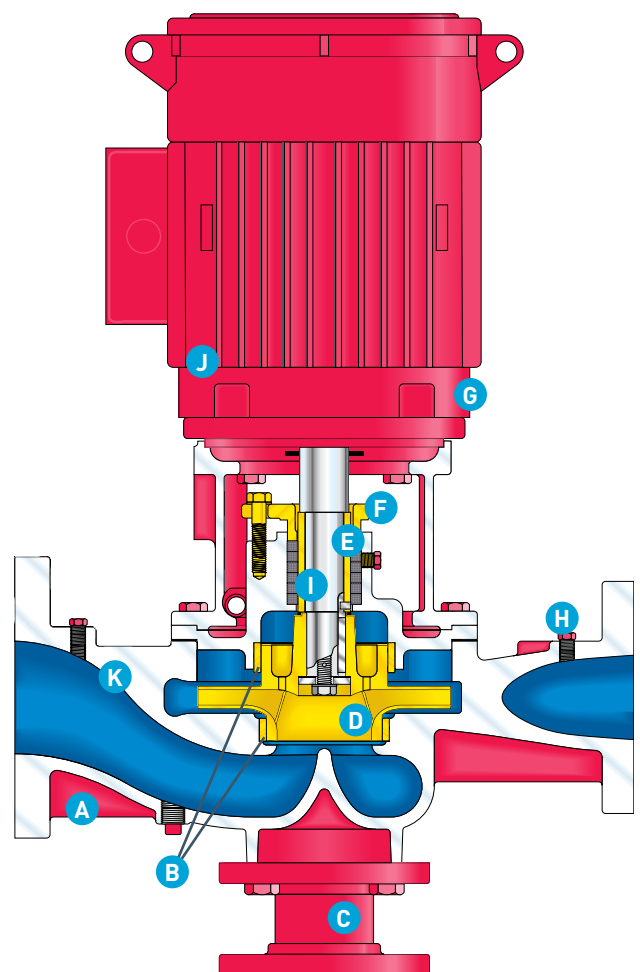

NOTE: Front case wearing rings are standard on all size pumps. Rear case rings are standard on all sizes except the 2 x 2 x 9C. The 2 x 2 x 9C does not require a wear ring.

# Engineering Specifications

## Engineering Specifications

One Aurora® model 383 vertical inline centrifugal Fire Pump listed by Underwriter's Laboratory and approved by Factory Mutual having a capacity of \_\_\_\_\_ GPM for a pressure boost of \_\_\_\_\_ psig. Pressure at the pump suction will be \_\_\_\_\_ psig, giving a discharge pressure of \_\_\_\_\_ psig. The pump shall have a bronze impeller, bronze case wear ring, packing gland and shaft sleeve. The pump discharge flange shall be \_\_\_\_\_ psi bolt pattern and the suction flange \_\_\_\_\_ psi bolt pattern. The pump shall be fitted with a Teflon® lantern ring when the suction pressure is 30 psig or less. Pump to be directly connected to a \_\_\_\_\_ hp \_\_\_\_\_ RPM vertical, solid shaft, open dripproof motor suitable for an electrical supply of \_\_\_\_\_ volts, \_\_\_\_\_ phase and \_\_\_\_\_ hertz with a 1.15 service factor.

## Testing

The pump shall be subjected to an operation test at rated speed. A performance curve showing the flow, total head, brake horsepower and efficiency is to be plotted. Certified curves shall be supplied to the customer. The pump shall be hydrostatically tested at two times the shut-off pressure or 250 psig, whichever is greater.



800 AIRPORT ROAD, NORTH AURORA, ILLINOIS 60542 WWW.AURORAPUMP.COM

Teflon® is a registered trademark of E.L. duPont

Aurora® is a registered trademark of Pentair Ltd.

Because we are continuously improving our products and services, Pentair reserves the right to change specifications without prior notice.

AF-02-1034 03/08/13 © 2013 Pentair Ltd. All Rights Reserved.

